

**AquFlow<sup>®</sup> - (Formerly Hydroflo) Metering Pumps**

# **AquFlow<sup>®</sup> Series 3000**

Hydraulically Actuated Diaphragm Metering Pump



**INSTALLATION, OPERATION AND  
MAINTENANCE MANUAL**

*This page intentionally blank.*

## Table of Contents

General Description .....	1
Principle of Operation .....	1
Installation Instructions	
Storage .....	2
Location .....	2
Piping - General .....	2
Suction Piping .....	2
Discharge Piping .....	3
Power Connections .....	4
Start-up Inspection .....	4
Pump Calibration .....	5
Maintenance Instructions	
Preventive Maintenance .....	6
Recommended Spare Parts .....	6
Oil Change .....	6
Check Valves .....	6
Diaphragm Replacement .....	7
Adjusting Internal Relief Valve .....	7
Pump Troubleshooting Chart .....	8
Spare Parts List	
Basic Drive Spare Parts - Cross Section .....	10
Basic Drive Spare Parts - List .....	11
Liquid End Spare Parts - Plastic .....	12
Liquid End Spare Parts - Metallic .....	13
Liquid End Spare Parts - Metallic .....	14
Notes .....	15
Spare Parts Ordering Instructions .....	back cover

## **Warranty**

AquFlow warrants its products against defects in workmanship or material under specified use and service for a period of 18 months from placement into service or 24 months from date of shipment. The obligation and liability of AquFlow is limited to repairing or replacing(at its option) such allegedly defective goods as are returned to AquFlow plant. No liability is assumed for removal or reinstallation costs, warrants of merchantability or fitness for a particular purpose except as specified. Liability for consequential damages (including personal injury) is hereby excluded; liability in any event being limited to the original purchase price of the good involved.

Defects shall not include decomposition by abrasion, chemical action, water, or caused by the presence of materials or conditions not specified. The component materials set forth in a proposal and/or the specifications of an order are recommended by AquFlow for the particular application.

But such recommendations shall not be construed as warranty or guarantee against wear and/or corrosion, such recommendations are subject in all cases to verification and acceptance by purchaser. Any warranty on equipment and accessories furnished by outside manufacturers shall be limited to the warranty of the respective equipment and/or accessory manufacturer of such goods. When repairs or replacements are made under our warranty, all freight costs will be paid by the purchaser.

AquFlow will not be responsible for the work performed by others. AquFlow reserves the right to void applicable warranties if work by others is determined by it to be improperly executed or not required.

**Please read this instruction manual before installing pump.**

In this instruction manual, the **Note**, **CAUTION** and **WARNING** notations have the following meanings:

**Note:** This heading is used if a special feature or operating requirement is being pointed out.

**CAUTION:** This heading is used to denote when failure to follow the operating instructions as prescribed herein can lead to pump or system damage.

**WARNING:** This heading is used to denote when failure to follow the operating instructions as prescribed herein could result in **PERSONAL INJURY!**

## GENERAL DESCRIPTION

Series 3000 is a industrial-duty positive displacement diaphragm metering pump, engineered to handle a wide range of chemicals and slurries.

These pumps consist of three major components: a motive power unit (typically a motor); a rotation to reciprocation conversion gearbox; and the liquid end assembly. Pump capacity is a function of drive speed, plunger diameter, and plunger stroke length. In these pumps, the plunger stroke length is fixed. An adjustable hydraulic bypass system allows changing the effective stroke length from 0 to 100%, which in turn determines capacity of process fluid delivered on each stroke of the pump.

Capacity is easily adjustable while the pump is running or stopped, using the standard manual micrometer stroke control or optional electronic or pneumatic capacity controls.

## PRINCIPLE OF OPERATION

On the Series 3000, hydraulic oil is displaced by the plunger into the diaphragm head area, in which a PTFE disc diaphragm separates the oil from the process fluid. The alternating displacement of oil by the plunger causes the diaphragm to flex, thereby displacing an equal volume of process fluid on the other side of the diaphragm.

Process fluid flow through the diaphragm head is controlled by ball check valves. During the pump's

suction stroke, the fluid is drawn into the liquid end; the suction check valve is open and the discharge valve is closed. When the stroke is reversed, discharge occurs; the suction valve is closed and the discharge valve is open.

The check valves close at the end of the suction and discharge strokes by hydraulic differential pressure and from their own weight, since they are gravity assisted.

Normal hydraulic oil losses are continually replenished on each stroke of the plunger. This is accomplished by mechanically opening the displacement chamber to the oil-filled gearbox for a short period at the end of every suction stroke and at the beginning of each discharge stroke. During this time, air and/or vapor is bled from the system, lost oil is replenished, and allowances made for expansion or contraction of hydraulic oil due to temperature fluctuations.

An internal hydraulic relief valve protects the pump and drive from damage that could result from over-pressure due to discharge pipeline restrictions.

Pumping accuracy is within  $\pm 1\%$  of set point under constant conditions of viscosity, vapor pressure, temperature, discharge pressure and capacity setting.

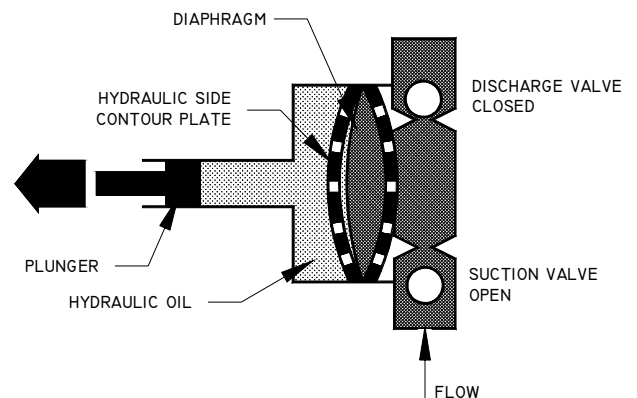

Figure 1. Suction Stroke

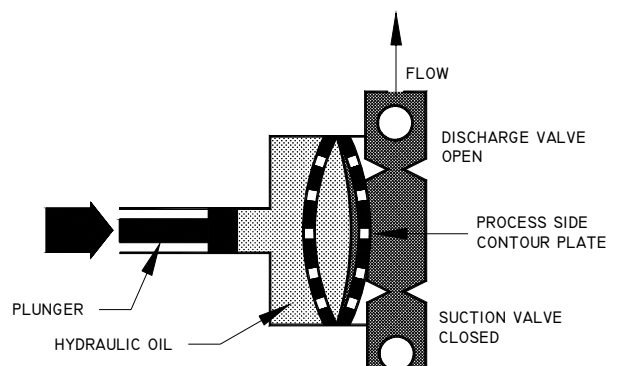

Figure 2. Discharge Stroke

## INSTALLATION INSTRUCTIONS

Prior to shipment, each pump is factory tested under application hydraulic conditions, using water. The internal relief valve is preset to meet the operating conditions specified on the purchase order, and the pump is fully assembled and ready for installation.

Protective caps are used to cover the suction and discharge check valves during shipment.

When unpacking the pump, make certain that no loose components are accidentally discarded. Examine the pump for shipping damage. If damage has occurred, a claim must be filed with the freight carrier within 24 hours.

## STORAGE

If the pump is not going to be installed immediately, but will be placed in storage for a period not to exceed 6 months, the following steps must be taken. Damage incurred as a result of improper storage protection will void the warranty.

1. Leave the pump in the original shipping carton and in an upright position, leaving all shipping plugs in place.
2. To protect critical internal components, make certain that pump is filled to capacity with hydraulic oil.
3. Store pump indoors or in a dry ambient controlled atmosphere to prevent temperature variations which may lead to condensation damage.
4. Contact the motor manufacturer for specific motor storage requirements.
5. Following storage, hydraulic oil must be changed prior to pump start-up.

**Note:** For storage in excess of 6 months, consult factory for long-term storage requirements.

## LOCATION

1. The pump installation site should provide easy access for capacity adjustment, routine maintenance, and where possible, to protect the pump from the elements and from leaks or drips from other process equipment.
2. The pump should be located on a level surface. While not required, it is suggested that the pump

be bolted on a concrete pad or slightly raised platform above floor level to protect pump from washdowns.

3. Pumps installed outdoors should be shaded from direct sunlight and protected from the elements. Direct sunshine and ambient temperatures above 90°F could cause excessive hydraulic oil and motor temperatures.

**Note:** Installations with ambient temperatures outside 50-100°F require changing the oil to a different viscosity index to assure reliable performance. In extreme cold temperatures, insulation and heat tracing may be required.

## PIPING

1. Series 3000 is a reciprocating motion type pump. Therefore, size the piping system to accommodate peak instantaneous flow which is 3.14 times pump capacity (example: 60 gph x 3.14 = 188 gph). Failure to do so may restrict fluid flows, resulting in erratic pump performance.
2. Piping materials selected must be resistant to corrosion by the liquid being pumped, and rated to withstand maximum pressure and temperatures of the system.
3. When determining pipe size, be certain that it is equal to, or the next size larger than, the pump check valve connections.
4. When selecting fittings for use with flexible hose or tubing, be certain that the I.D. is equal to or larger than that of the tubing. Failure to do so may restrict fluid flows, resulting in erratic pump performance.
5. Use pipe sealant(s) sparingly. Excess sealant could dislodge and impede proper check valve operation. Be particularly careful when making pipe connections to plastic pump heads, since use of excessive sealant and/or overtightening may crack plastic pump heads.
6. Shut-off valves and unions installed in the suction and discharge pipelines will facilitate pump servicing.

## SUCTION PIPING

1. Before connecting the pump, **be certain that the suction piping is completely clean by flushing thoroughly.** Failure to do so may result in foreign matter entering and damaging the pump.

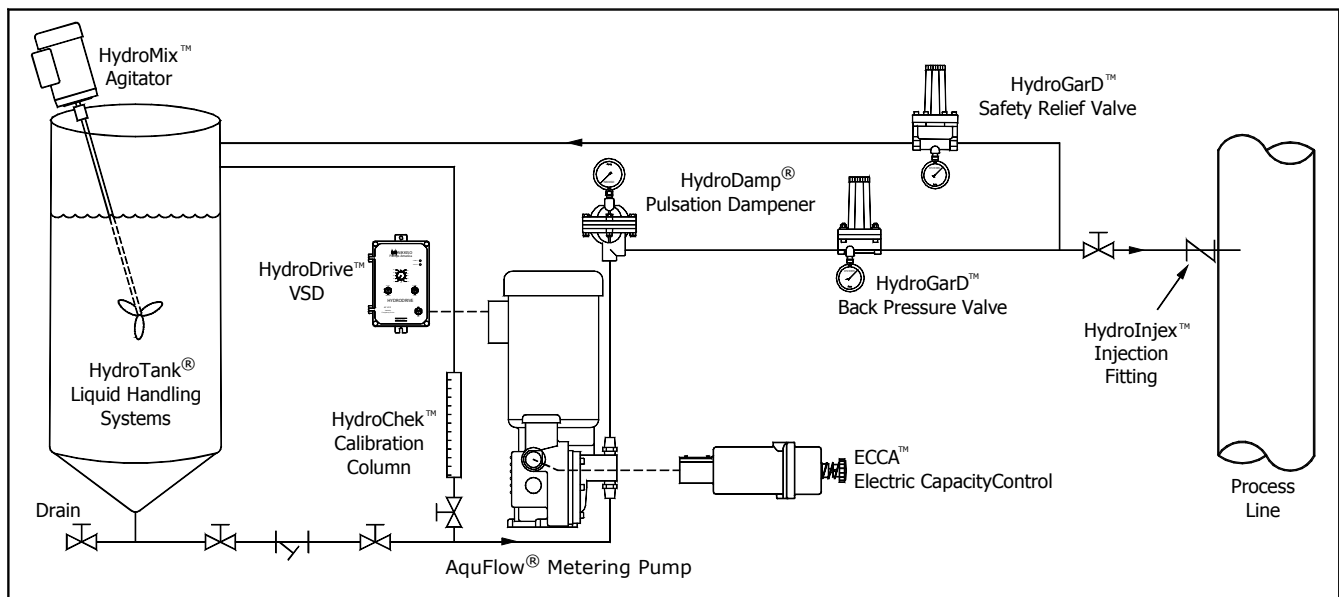

**Figure 3. Typical Metering Pump Installation**

2. Keep the suction line as short and straight as possible. A flooded suction or gravity feed of the process fluid to the pump inlet is preferred. **A suction line strainer is highly recommended** to prevent foreign matter from entering and damaging the pump.

**Note:** Suction lift applications require the use of a foot valve and strainer to prevent loss of prime and to prevent foreign material from entering the pump.

3. Suction piping must be absolutely airtight to assure accurate pumping. If air or gas is allowed to accumulate inside the pumphead, the output will become erratic or stop altogether.
4. Piping should be sloped to prevent the formation of vapor pockets, which could eventually accumulate inside the pumphead resulting in erratic pump delivery.
5. Do not spring the piping when mating it to the pump. Provide necessary pipe supports to avoid placing strain on the pump connections. Flexible connections can be used if pressure permits. If flexible suction line is used, be sure that selection and installation will prevent wall collapse and thus a starved suction condition.

6. Provision should be made in the system to avoid the possibility of running the pump dry. Typically this is accomplished by wiring a low-level shut-off switch mounted in the supply tank to the pump motor starter as shown in Figure 4.
7. Where pump fluids may solidify, crystallize, etc., provision should be made to flush the pump and piping regularly, especially prior to shutdown.

### DISCHARGE PIPING

1. Install adequately sized pipe with a pressure rating in excess of the pressure relief valve setting.
2. A minimum positive pressure differential of 25 psi between the suction and discharge valves is recommended for proper hydraulic bypass operation and seating of the ball checks. Should normal discharge pressure be less than the suction pressure, an artificial discharge pressure must be created to prevent siphoning. This can be accomplished by the use of an AquFlow HydroGarD™ back pressure valve installed in the discharge piping as shown in Figure 3 above.
3. A properly sized pulsation dampener installed in the discharge pipeline between the pump and back pressure valve will smooth out flow peaks, reduce “water hammer” and protect downstream instrumentation.

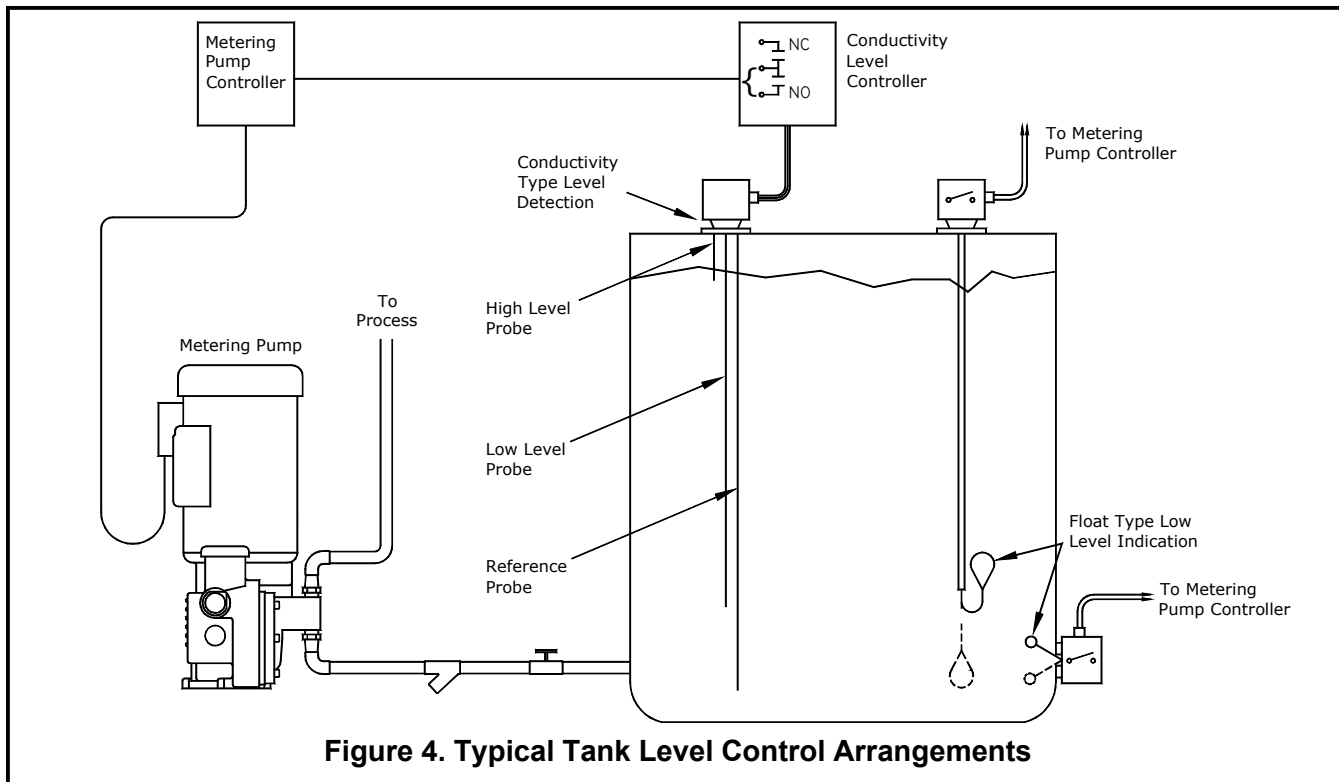

**Figure 4. Typical Tank Level Control Arrangements**

4. For additional safety, a Hydrolnject™ Assembly should be installed at the point where the discharge line enters a boiler, other high-pressure process vessel or any pressurized system.

**CAUTION:** The internal relief valve is designed only to protect the pump and drive components in the event the piping system is restricted or blocked while the pump is in operation.

If there are other sources of pressure or hydraulically isolated sections of piping in the system, an external safety relief valve must be installed in the pump discharge line as close to the pump as possible, and BEFORE any isolation valve. The safety relief valve should be piped back to the suction tank or safety drain as shown in Figure 3.

## POWER CONNECTIONS

1. Check the nameplate rating of the motor and any auxiliary electrical equipment against the available power supply before making connections. Direction of rotation of the motor is important, and must be clockwise when viewing the motor from the top. Jog the motor to check rotation.

2. Standard wiring and conduit piping practice in accordance with local electrical codes should be followed. A motor starter with properly sized thermal overload heater is recommended.
3. Provide adequate ventilation for the drive motor.

**CAUTION:** Motor starters with properly sized thermal overload are recommended for motor protection. These are typically supplied by others!

**Note:** Motors are warranted by the motor manufacturer. You can obtain prompt local service by consulting the motor manufacturer's authorized service station nearest you, as listed on the Internet or in the yellow pages. NPA can also assist you in locating this information.

Please do not return motors directly to NPA, as this will only delay warranty service.

## START-UP INSPECTION

Several items should be checked after the pump has been installed and prior to initial start-up.

1. Series 3000 pumps are shipped with hydraulic oil filled to the correct level.



**Note:** Installations with ambient temperatures outside 50-100°F require changing the oil to a different viscosity index to assure reliable performance. In extreme cold temperatures, insulation and heat tracing may be required.

Remove the reservoir cover and confirm the hydraulic oil reaches the level mark shown on the pump housing.

2. After initial filling, run the pump for 15 minutes with micrometer knob set at 0% to allow hydraulic oil to completely fill all pump cavities, then recheck level and add oil as necessary. Smaller plunger size pumps may require longer running at 0% micrometer setting to fully vent entrained air from the hydraulic oil.
3. Check to be certain that the electrical supply matches the pump nameplate electrical characteristics.
4. Check to be certain that accessory components and fittings have been installed in the proper orientation and sequence as shown in Figure 3.
5. Jog motor to assure proper clockwise rotation.
6. Make certain that suction and discharge valves are open prior to pump start-up.
7. It is important that pump suction and discharge lines are free of entrained air. To assure proper start-up, start the pump without any discharge pressure (vented to atmosphere) and with the micrometer set at 0% capacity. Slowly turn the micrometer towards 100% capacity to fill the pumping system with process fluid.

**Note:** On suction lift applications, it may be necessary to prime the pump by first wetting the ball check valves, and starting the pump without any discharge pressure (vented to atmosphere). Suction lift applications require the use of a foot valve strainer to prevent loss of prime.

## PUMP CALIBRATION

Each pump is tested at the factory prior to shipment to assure proper operation at the capacity and discharge pressure specified. For precise capacity control in the field, a calibration test under actual pumping and piping conditions is recommended.

This can be accomplished by allowing the pump to operate at full capacity for a minimum of 30 minutes. This will clear any air out of the pump.

Pump calibration can be accomplished by measuring the decrease in liquid level pumped from a HydroChek™ calibration column installed in the suction line as shown in Figure 3 on page 3. Follow the calibration instructions provided by the cylinder manufacturer.

An alternate method of calibration for non-hazardous applications is to collect and measure the fluid metered from the pump discharge port into a graduated cylinder or tank.

Typically, test samples are collected at 25%, 50%, 75% and 100% capacity settings. A straight line results when these points are plotted on a graph. This graph can then be used for intermediate settings, assuming suction and discharge conditions remain constant.

**WARNING:** Use extreme care when performing calibration test using open cylinder or tank method, and be extremely careful when working in the presence of hazardous substances.

**Wear suitable protective clothing and eye shielding for protection.**

It is important to realize that the samples at 50% will not necessarily be exactly 1/2 of that at 100%, nor will any other sample points be a specific percentage of the 100% value. But, the sample value will lie along a straight line that can be used for intermediate settings, and the pump will give repetitive samples at the same setting. This last characteristic is what makes the Aquflow® Series 3000 pump effective; it will meter chemicals precisely within ±1% of capacity set point over long periods of time.

Also, as operating discharge pressures increase, there are additional hydraulic system losses which are constant for any given discharge pressure.

This results in a small decrease in the maximum capacity output on the pump. All NIKKISO Hydroflo® capacity/pressure charts used for pump selection have a base pressure rating of 100 psig. For higher discharge pressure decrease maximum capacity by 1.25% for every 100 psig increase.

## MAINTENANCE INSTRUCTIONS

**WARNING:** Disconnect and lockout power to the pump before performing service or disassembling the pump.

## PREVENTATIVE MAINTENANCE

The Series 3000 metering pump is designed for continuous service with maximum reliability and minimum downtime. However, good maintenance procedures dictate that certain visual periodic checks be made to assure that operating problems have not developed.

1. Check the hydraulic oil level periodically, to be sure it is at the proper level mark, and adjust as necessary.
2. Inspect the liquid end assembly, including the suction and discharge connections for any indication of leakage, and correct as necessary.
3. Hydraulic oil should be replaced once a year following the procedures outlined under "Oil Change."

## RECOMMENDED SPARE PARTS

To minimize downtime, a Spare Parts Pak should be inventoried to support each pump. These Parts Paks are available in vacuum-sealed packaging, which provides extended shelf life when properly stored.

- (1) Diaphragm
- (1) Diaphragm O-Ring
- (2) Check Valve Seats
- (2) Check Valve Guides
- (2) Check Valve Balls
- (2) Check Valve O-Rings
- (1) Drive Lubricant Change
- (2) Gear Shaft O-Rings

**Note:** Multiplex pumps require one (1) Spare Parts Pak for each liquid end.

## OIL CHANGE

1. Under normal operating conditions the hydraulic oil should be drained and replaced once a year. In severe applications the hydraulic oil should be changed more frequently.

2. Drain hydraulic oil using the drain plug on the side of the pump. (For convenience the drain plug can be replaced with a quick draw fitting or valve and short nipple.)

The recommended lubricant for AquFlow® Series 3000 is Zurn E.P. #95, for normal operation. Various manufacturers' equivalent oils are listed below:

(Indoor, temperature controlled ambient)

ZURN	EP Lube #EP95
Amoco	Permagear #220
Drydene	E.P. Gear Oil #5
Exxon	Spartan #EP220
Mobil	Mobilgear #630
Shell	Omala #220
Texaco	Meropa #220

**Note:** Installations with ambient temperatures outside 50-100°F require changing the oil to a different viscosity index to assure reliable performance. In extreme cold temperatures, insulation and heat tracing may be required.

For applications with different ambient or fluid temperatures, please consult factory for alternate lubricant recommendations.

## CHECK VALVES

1. Hydroflo® check valve assemblies utilize oversized balls and are designed to be self-cleaning, and should seldom need service.
2. Fouled metallic check valves can usually be cleaned in a mild solvent solution, followed by a clean water flush. Blow check valve assembly dry using clean compressed air. The check valve ball should be free falling within the valve body.
3. Plastic check valves must be disassembled to facilitate cleaning. It is recommended that new o-rings be installed during reassembly.
4. Repair or replace any check valve components that exhibit damage or wear from chemical corrosion. Ball check valves can be tested for proper sealing by filling ball/seat area with water. For the check valve to be usable it must hold a five foot column of water for 30 seconds without leaking.

## DIAPHRAGM REPLACEMENT

Except in the unlikely event of a loss in integrity, the diaphragm does not require replacement. Should a diaphragm replacement be required, the following steps must be followed:

### DISASSEMBLY

1. Wear suitable protective clothing and eye shielding for protection.
2. Disconnect and lockout electrical power to the pump and drain hydraulic oil.
3. Isolate and disconnect the piping from the suction and discharge check valves.
4. Flush process fluid from liquid end, using a suitable neutralizing agent.
5. Remove the bolts from the liquid end and remove it from the drive housing. Note the orientation of the check valve cartridges prior to removing the diaphragm head, as they must be in the same position when diaphragm head is reassembled.
6. Remove diaphragm, contour plate and support plate; inspect for any obvious damage.

**Note:** To prevent leakage, never attempt to reuse the old diaphragm.

### REASSEMBLY

1. Set oil side contour plate in displacement chamber.
2. Set new diaphragm in head over contour plate.
3. Mount diaphragm head assembly to displacement chamber with bolts. If necessary, hold diaphragm and contour plate in place using a thin, flat, smooth tool such as a machinists' ruler until head is positioned on the displacement chamber.
4. Remove tool carefully while holding head in place.
5. Refill hydraulic system with oil by fill reservoir chamber to recommended level.
6. Reconnect suction and discharge lines.
7. Follow the "Start Up Inspection" procedure as outlined earlier. Run the pump; check for leaks.
8. Return the pump to service.

## ADJUSTING INTERNAL RELIEF VALVE

The internal relief valve is factory set to open at a pressure slightly higher than the discharge pressure indicated on the pump dataplate. Never set the value higher than 15% above maximum discharge pressure.

1. Wear suitable protective clothing and eye protection.
2. To access the internal relief valve, remove the oil reservoir cover by loosening the cover screw or turning cover counterclockwise.
3. To adjust relief valve, first operate pump against system operating pressure.
4. Stop pump.
5. Install a pressure gauge, with a range of 50% higher than the desired relief pressure, at the pump discharge connection.
6. Install a shut off valve downstream from the pressure gauge.
7. Open the shut off valve and start pump. Pump process liquid to drain or other safe place to establish proper pumping action.
8. Set pump capacity control at 100%.
9. Close shut off valve, thus "deheading" the pump, and closing watch pressure increase on the pressure gauge. If the pressure exceeds the desired relief setting, quickly open the shut off valve to relieve the pressure in the line.
10. Loosen relief valve adjusting screw by turning counter clockwise in small increments, and repeat step 8 until the maximum gauge reading equals the desired relief valve pressure setting.
11. After setting the relief valve, be certain shut off valve is fully open. Remove pressure gauge and place pump in routine service.

**WARNING:** Do not run pump with relief valve adjuster "bottomed out," as severe damage to pump may result!

Never exceed pressure rating of pump or any component of the system or piping!

When the relief valve is actuated, particularly in the larger plunger size or high-speed units, oil may be ejected at high velocity through the bypass port. Routine precautions should be taken to prevent oil from splashing the operator of the surrounding area!

## Pump Troubleshooting Chart

The following charts cover common problems, probable causes and remedies as related to metering pump operation, and will serve as a basis to help isolate and remedy these problems. Each section lists probable causes and remedies in systematic order of probability.

### MOST COMMON STARTUP PROBLEMS

	PROBABLE CAUSE	REMEDIES
<p>Most problems that arise during or shortly after startup are a result of improper pump installation.</p> <p>Each Hydroflo pump is tested and in good working order when shipped. Before making adjustments to, or disassembling any part of the pump, check the following.</p>	<ol style="list-style-type: none"> <li>1. Insufficient hydraulic oil.</li> <li>2. Clogged or blocked ball check valves, or check valves held open by solids.</li> <li>3. Clogged/blocked suction strainer.</li> <li>4. System discharge pressure greater than pump relief valve setting.</li> <li>5. Starved suction.</li> </ol>	<ol style="list-style-type: none"> <li>1. Fill to proper level.</li> <li>2. Clean or replace (suction line not flushed prior to connecting pump, permitting debris to enter and block ball check valves).</li> <li>3. Clean or replace.</li> <li>4. Reset internal relief valve within pump rating.</li> <li>5. Insufficient NPSH<sub>A</sub>. Shorten suction piping; increase suction pipe size; increase suction head.</li> </ol>

PROBLEM	PROBABLE CAUSE	REMEDIES
Pump motor fails to start.	<ol style="list-style-type: none"> <li>1. Blown fuse or tripped breaker.</li> <li>2. Open thermal overload.</li> <li>3. Low line voltage.</li> <li>4. Open circuit in limit switches, timers or other control devices in pump motor starter circuit.</li> <li>5. Motor damage.</li> </ol>	<ol style="list-style-type: none"> <li>1. Replace fuse after correcting cause of overload.</li> <li>2. Reset after correcting cause of overload; check heater size.</li> <li>3. Determine cause and correct.</li> <li>4. Reset.</li> <li>5. Check motor for physical damage that may hinder operation.</li> </ol>
Pump runs but fails to deliver.	<ol style="list-style-type: none"> <li>1. Insufficient hydraulic oil.</li> <li>2. Check valve(s) lodged open by solids.</li> <li>3. Worn or dirty ball check valves.</li> <li>4. Suction or discharge line blocked.</li> <li>5. Isolation valve closed.</li> <li>6. Pump is not primed.</li> <li>7. Check valves installed incorrectly.</li> <li>8. Solids build-up between diaphragm and contour plate, limiting diaphragm movement.</li> </ol>	<ol style="list-style-type: none"> <li>1. Fill to proper level.</li> <li>2. Clean or replace.</li> <li>3. Clean or replace.</li> <li>4. Clean line.</li> <li>5. Open valve.</li> <li>6. Allow suction line and pump head to fill with liquid before pumping against pressure.</li> <li>7. Remove and reinstall correctly.</li> <li>8. Remove and clean liquid end, replace diaphragm. An infrequent occurrence when pumping fluid that contains particles that settle out. (A tubular diaphragm liquid end recommended.)</li> </ol>

## Pump Troubleshooting Chart (continued)

PROBLEM	PROBABLE CAUSE	REMEDIES
Pump fails to deliver rated capacity.	<ol style="list-style-type: none"> <li>1. Incorrect capacity setting.</li> <li>2. Insufficient hydraulic oil.</li> <li>3. Starved suction.</li> <li>4. Internal or external relief valve set too low for system conditions.</li> <li>5. Leaky suction piping.</li> <li>6. Excessive suction lift.</li> <li>7. Fluid close to boiling point.</li> <li>8. Fluid viscosity too high.</li> <li>9. Worn or dirty ball check valves.</li> </ol>	<ol style="list-style-type: none"> <li>1. Readjust capacity setting.</li> <li>2. Fill to proper level.</li> <li>3. Increase suction piping size or increase suction head.</li> <li>4. Reset valve to correct setting.</li> <li>5. Repair piping.</li> <li>6. Decrease lift.</li> <li>7. Cool liquid; increase suction head.</li> <li>8. Reduce viscosity of fluid; change ball material; increase ball size.</li> <li>9. Clean or replace.</li> </ol>
Pump operates erratically.	<ol style="list-style-type: none"> <li>1. Clogged/dirty suction strainer.</li> <li>2. Insufficient hydraulic oil.</li> <li>3. Leak in suction piping.</li> <li>4. Internal external relief valve is relieving.</li> <li>5. Insufficient suction pressure.</li> <li>6. Worn or dirty ball check valves.</li> <li>7. Fluid too close to boiling point.</li> <li>8. Fluid viscosity too high.</li> </ol>	<ol style="list-style-type: none"> <li>1. Clean strainer.</li> <li>2. Fill to proper level.</li> <li>3. Repair piping.</li> <li>4. Reset relief valve.</li> <li>5. Raise tank fluid level.</li> <li>6. Clean or replace.</li> <li>7. Cool fluid or increase suction head.</li> <li>8. Reduce viscosity of fluid; change ball material; increase ball size.</li> </ol>
Pump delivers too much capacity.	<ol style="list-style-type: none"> <li>1. Insufficient discharge pressure.</li> <li>2. Too much suction pressure.</li> </ol>	Increase discharge pressure (pump discharge pressure must be 25-30 psig greater than suction pressure to assure proper ball check valve operation).
Noisy operation.	<p>Ball check valves.</p> <ol style="list-style-type: none"> <li>1. Excessive gear wear.</li> <li>2. Improper lubrication.</li> <li>3. Worn bearings.</li> </ol>	<p>Ball valves makes a clicking sound as they operate - rattling noises may also be heard. Under certain conditions these noises are amplified by the natural resonance of piping. These noises are normal and should not cause concern.</p> <ol style="list-style-type: none"> <li>1. Replace gear set.</li> <li>2. Replace with correct oil.</li> <li>3. Replace bearings.</li> </ol>
Motor overheats.	<ol style="list-style-type: none"> <li>1. Motor overloaded - pump operating in excess of discharge pressure rating.</li> <li>2. Improper wiring or low voltage.</li> <li>3. Hydraulic oil too viscous.</li> <li>4. High ambient temperature.</li> </ol>	<ol style="list-style-type: none"> <li>1. Limit discharge pressure to the maximum pressure specified.</li> <li>2. Check power supply.</li> <li>3. Drain/refill with correct oil.</li> <li>4. Increase ventilation or relocate pump.</li> </ol>
Pump leaking oil.	<ol style="list-style-type: none"> <li>1. Oil drain plug loose.</li> <li>2. Pump overfilled with hydraulic oil.</li> <li>3. Diaphragm head bolts loose.</li> </ol>	<ol style="list-style-type: none"> <li>1. Tighten.</li> <li>2. Drain oil to proper level.</li> <li>3. Tighten to specifications.</li> </ol>
Pump losing oil. Hydraulic oil discolored.	Ruptured diaphragm.	Replace diaphragm after correcting cause of failure. Hydraulic oil must be discarded and the pump gearbox thoroughly flushed of all traces of process fluid. Replace with fresh hydraulic oil.

# Basic Drive Spare Parts - Cross Section

REVISIONS			
REV	DESCRIPTION	DATE	BY
F	PAPER FILE	5/28/93	RDH
G	REDRAWN	6/26/01	CG
			WN

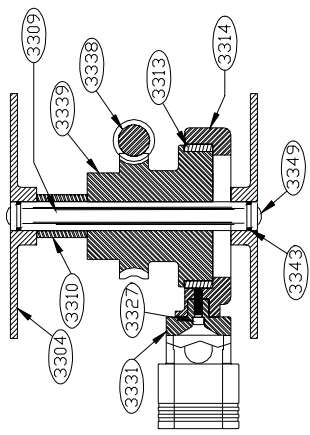
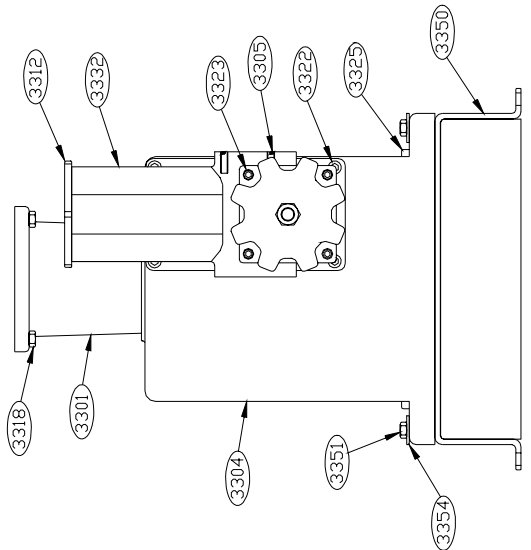
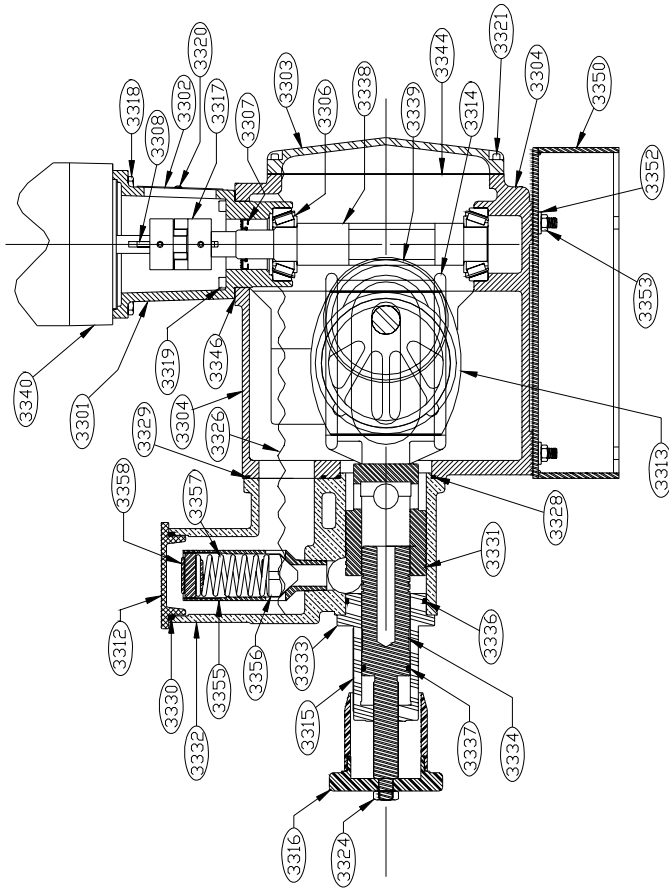

SHOP ORDER NO:	FILE NAME:
DRAWN BY: CSC	6100 Easton Road Plumsteadville, PA 18949
CHK'D BY:	TITLE
APP'D BY: WN	CROSS SECTION SERIES 3000 DRIVE UNIT SIMPLEX
DATE: 06/21/01	SIZE P/N PREFIX DWG NO 13034
DO NOT SCALE DWG	B HF G
	SCALE 1/4
	SHEET 1 OF 2

THIS DRAWING AND ALL INFORMATION CONTAINED THEREIN IS AND REMAINS THE PROPERTY OF NIKKISO PUMPS AMERICA AND IS CONFIDENTIAL. IT IS SUBMITTED AND MAY BE USED ONLY IN CONNECTION WITH PENN. NIKKISO PUMPS AMERICA PROPOSAL AND SHALL BE IMMEDIATELY RETURNED TO NIKKISO PUMPS AMERICA UPON REQUEST.

# Basic Drive Spare Parts - List

ITEM QTY		DESCRIPTION	REVISIONS			
			REV	DESCRIPTION	DATE	BY
			H	PARTS LIST CORRECTION SHT. 2	7/10/01	CG
						WN

ITEM QTY	DESCRIPTION	ITEM QTY	DESCRIPTION	ITEM QTY	DESCRIPTION
3301	ADAPTOR, MOTOR, NEMA C FACE	3323	4 SCREW, ADJUSTER HOUSING	* 3350	1 BASEPLATE
3302	COVER, ADAPTOR	3324	1 NUT, CAPACITY ADJUSTER	* 3351	4 BOLT, BASEPLATE
3303	COVER, REAR	3325	2 PLUG, OIL DRAIN	* 3352	4 LOCKWASHER, BASEPLATE
3304	HOUSING, GEAR	3326	2 OIL, HYDRAULIC (GAL)	* 3353	4 NUT, BASEPLATE
3305	0-RING, MOUNTING PLATE	3327	1 SCREW, PLUNGER	* 3354	4 WASHER, BASEPLATE
3306	BEARING, ROLLER	3328	1 O-RING, HOUSING LOWER	3355	1 BODY, RELIEF VALVE
3307	OIL SEAL	3329	1 O-RING, HOUSING UPPER	3356	1 POPPET, RELIEF VALVE
3308	KEY, COUPLING	3330	1 O-RING, COVER CHAMBER	3357	1 SPRING, RELIEF VALVE
3309	GEARSHAFT	3331	1 PLUNGER	3358	1 ADJUSTER, RELIEF VALVE
3310	SPACER, GEARSHAFT	3332	1 CHAMBER, PRESSURE		
3312	COVER, PRESSURE CHAMBER	3333	1 HOUSING, ADJUSTER		
3313	BEARING, CROSSHEAD	3334	1 ADJUSTER		
3314	CROSSHEAD	3336	1 O-RING, HOUSING ADJUSTER		
3315	CAPACITY PLATE	3337	1 O-RING, ADJUSTER		
3316	HANDWHEEL, MICROMETER	3338	1 WORM		
3317	COUPLING SET	3339	1 GEAR		
3318	4 BOLT, MOTOR MOUNTING	3340	1 MOTOR, NEMA C FACE		
3319	4 SCREW, ADAPTOR	3343	2 O-RING, GEARSHAFT		
3320	2 SCREW, COVER ADAPTOR	3344	AR SEALANT, SILICONE		
3321	8 SCREW, REAR COVER	3346	AR SHIM		
3322	6 SCREW, PRESSURE CHAMBER	3349	2 SCREW, GEARSHAFT		

\* = INCLUDED WHEN PUMP IS EQUIPPED WITH NON METALLIC LIQUID END

SHOP ORDER NO: \_\_\_\_\_

FILE NAME: \_\_\_\_\_

DRAWN BY: CSG	6100 Easton Road Plumsteadville, PA 18949	
CHK'D BY:	TITLE	CROSS SECTION
APP'D BY: WN		SERIES 3000
DATE: 07/01/01		DRIVE UNIT
	SIZE P/N PREFIX	DWG NO
	B HF	13034
DO NOT SCALE DWG	SCALE FULL	SHEET 2 OF 2
THIS DRAWING AND ALL INFORMATION CONTAINED THEREIN IS AND REMAINS THE PROPERTY OF NIKKISO PUMPS AMERICA AND IS CONFIDENTIAL. IT IS SUBMITTED AND MAY BE USED ONLY IN CONNECTION WITH PENN NIKKISO PUMPS AMERICA PROPOSAL AND/OR IT'S CUSTOMER'S ORDERS. IT SHALL NOT BE DISCLOSED TO OTHERS OR COPIED WITHOUT NIKKISO PUMPS AMERICA WRITTEN CONSENT AND SHALL BE IMMEDIATELY RETURNED TO NIKKISO PUMPS AMERICA UPON REQUEST.		

MODEL AND SERIAL NUMBER REQUIRED WHEN ORDERING PARTS

# Liquid End Spare Parts - Plastic

## REVISIONS

REV	DESCRIPTION	DATE	BY	APP'D
E	REDRAWN	6/29/01	CG	WN
F	PARTS LIST CORRECTION	7/10/01	CG	WN

ITEM QTY	DESCRIPTION	RECOMMENDED SPARE PTS. *	TORQUE IN LBS
9001 4	NUT		50
9002 4	LOCK WASHER		
9003 4	BOLT, TEE		50
9004 2	YOLKE		
9005 2	STUD		
9006 2	O-RING, CONNECTOR	2	
9007 2	BALL	2	
9008 1	TEE		
9009 1	PLATE, TEE		
9010 2	O-RING, SEAT	2	
9011 2	GUIDE, BALL	2	
9012 2	SEAT	2	
9013 2	CONNECTOR	2	
9014 8	BOLT, DIAPHRAGM HEAD		60
9015 1	PLATE, DIAPHRAGM HEAD		
9017 1	DIAPHRAGM	1	
9019 4	BOLT, MOUNTING PLATE		110
9021 1	PLATE, MOUNTING		
9022 1	HEAD, DIAPHRAGM		
9023 1	PLUG, DIAPHRAGM HEAD		
9024 1	O-RING, TEE	1	
9025 1	PLATE, BACK-UP		
2912 1	VALVE, BLEED		
2548 1	O-RING, DIAPHRAGM	1	

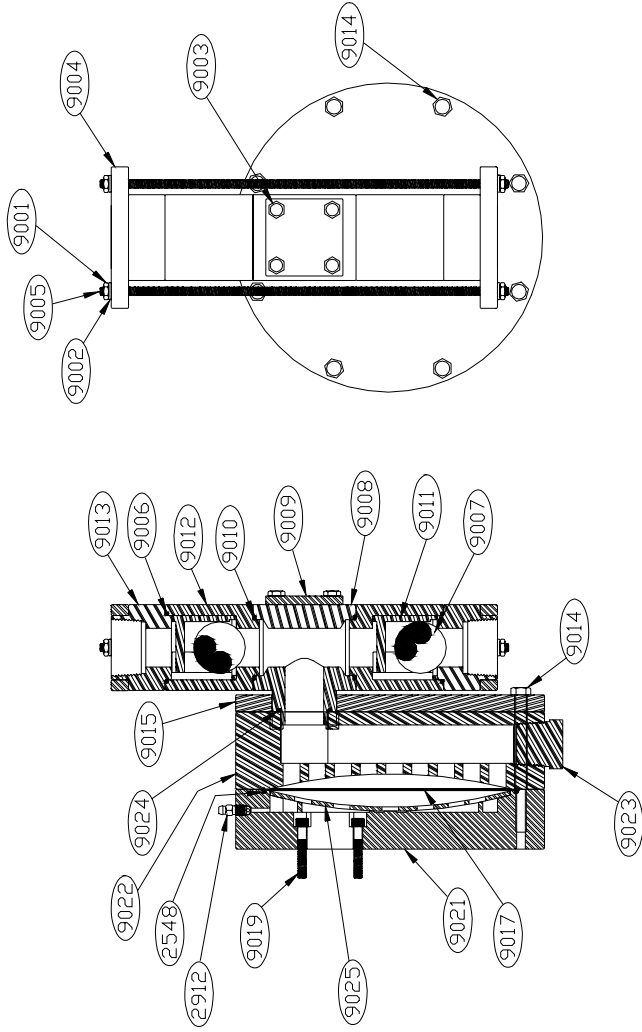

SHOP ORDER NO:

FILE NAME:

DRAWN BY: CSG		6100 Easton Road Plumsteadville, PA 19349
CHK'D BY:	TITLE	CROSS SECTION & PARTS LIST
APP'D BY: WN		NON METALLIC LIQUID END SERIES 3000 9" HEAD
DATE: 6/29/01	SIZE	P/N PREFIX DWG NO 13128
DO NOT SCALE DWG	SCALE	B HF 13128
		REV F
		SHEET 1 OF 1

THIS DRAWING AND ALL INFORMATION CONTAINED THEREIN IS AND REMAINS THE PROPERTY OF NIKKISO PUMPS AMERICA AND IS CONFIDENTIAL. IT IS SUBMITTED AND MAY BE USED ONLY IN CONNECTION WITH PENN NIKKISO PUMPS AMERICA PROPOSAL AND SHALL BE IMMEDIATELY RETURNED TO NIKKISO PUMPS AMERICA UPON REQUEST.

\* MODEL AND SERIAL NUMBER REQUIRED WHEN ORDERING SPARE PARTS



# Liquid End Spare Parts - Metallic

REV	DESCRIPTION	DATE	BY	APP'D
G	REDRAW	05/31/02	CC	WN

## REVISIONS

ITEM QTY	DESCRIPTION	RECOMMENDED SPARE PTS. *	TORQUE IN LBS
2548 1	O-RING, DIAPHRAGM	1	
2912 1	VALVE, BLEED		
3003 8	BOLT, DIAPHRAGM HEAD	300	
3004 1	HEAD, DIAPHRAGM		
3005 1	PLATE, CONTOUR		
3006 4	BOLT, TEE	300	
3011 1	TEE		
3018 1	O-RING, TEE	1	
3022 2	O-RING, MALE BODY	2	
3023 2	BODY, FEMALE	2	
3025 2	BODY, MALE	2	
3028 2	BALL, CHECK VALVE	2	
3029 2	GUIDE, CHECK VALVE BALL	2	
9017 1	DIAPHRAGM	1	
9019 4	BOLT, MOUNTING PLATE		
9021 1	PLATE, MOUNTING		
9025 1	PLATE, BACK-UP		

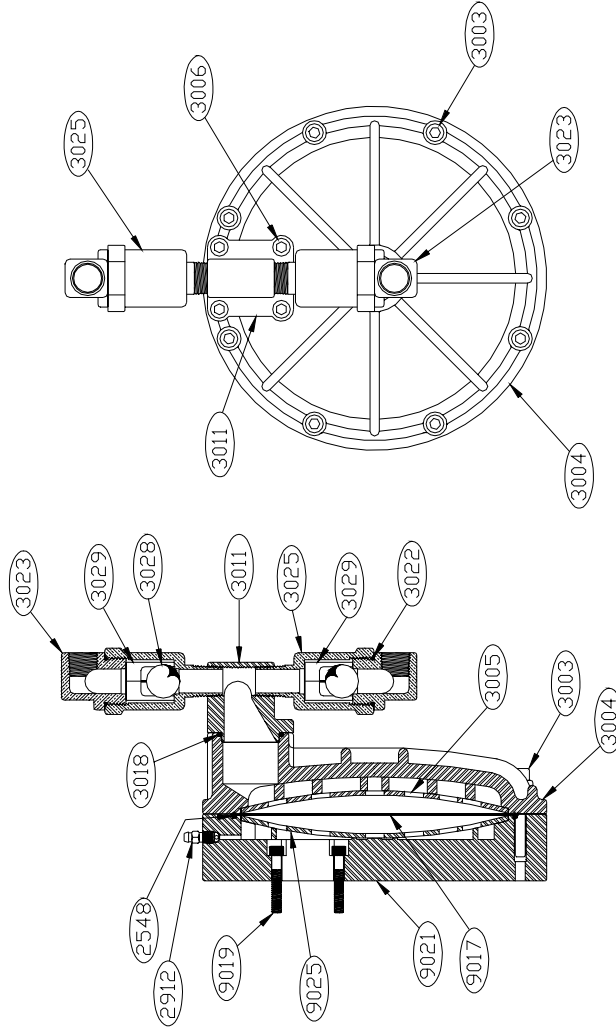

SHOP ORDER NO: \_\_\_\_\_ FILE NAME: \_\_\_\_\_

DRAWN BY: CSG 6100 Easton Road Plumsteadville, PA 18949

CHK'D BY: \_\_\_\_\_

APP'D BY: WN TITLE CROSS SECTION & PARTS LIST

DATE: 05/31/02 SERIES 3000 9" HEAD METALLIC LIQUID END 7/8 CHECK VALVES

DO NOT SCALE DWG SIZE P/N PREFIX DWG NO 13132 REV B HF G

SCALE SHEET 1 OF 2

THIS DRAWING AND ALL INFORMATION CONTAINED THEREIN IS AND REMAINS THE PROPERTY OF NIKKISO PUMPS AMERICA AND IS CONFIDENTIAL. IT IS SUBMITTED AND MAY BE USED ONLY IN CONNECTION WITH FENN NIKKISO PUMPS AMERICA PROPOSAL AND/OR ITS CUSTOMER'S ORDERS. IT SHALL NOT BE DISCLOSED TO OTHERS OR COPIED WITHOUT NIKKISO PUMPS AMERICA WRITTEN CONSENT AND SHALL BE IMMEDIATELY RETURNED TO NIKKISO PUMPS AMERICA UPON REQUEST.

\* MODEL AND SERIAL NUMBER REQUIRED WHEN ORDERING SPARE PARTS





PARTS ORDERING INSTRUCTIONS

Always have the complete pump model and serial number available when contacting NPA for parts or service. This model number can be found on the data plate mounted on the back of the pump housing.

**AquFlow®**  
CHEMICAL METERING PUMP

MODEL	CNIT 0888-04018	
SERIAL	1234567	
CAPACITY	48.4	GPH
PRESSURE	675	PSIG

NIKKISO Pumps America, Inc.  
[www.nikkisopumpsamerica.com](http://www.nikkisopumpsamerica.com)

Should it be necessary to send the pump to the factory for repair or service, thoroughly flush the pump liquid end of all process fluid, drain all hydraulic oil, and call factory for a return authorization number. A material safety data sheet (MSDS) will be required. Pumps returned without authorization number will not be accepted.

Direct all inquiries and orders to your local representative or directly to:

AquFlow  
17865 Skypark Circle, Unit M  
Irvine CA 92614  
Telephone: (949) 757-1753  
Fax: (949) 757-1687  
[www.aquflow.com](http://www.aquflow.com)  
[sales@aquflow.com](mailto:sales@aquflow.com)

FOR YOUR CONVENIENCE, RECORD PUMP SERIAL  
NUMBER HERE: \_\_\_\_\_ .

© 2002 NPA



**AquFlow**  
17865 Skypark Circle, Unit M • Irvine CA 92614  
Phone (949) 757-1753 • Fax: (949) 757-1687  
email: [sales@aquflow.com](mailto:sales@aquflow.com)  
<http://www.sales@aquflow.com>

Printed in U.S.A. 09/02