

**AquFlow - (Formerly Hydroflo) Metering Pumps**

# **AquFlow Series 1000**

Hydraulically Actuated Diaphragm Metering Pump



**INSTALLATION, OPERATION AND  
MAINTENANCE MANUAL**

*This page intentionally blank.*

# Table of Contents

Warranty .....	ii
General Description .....	1
Principle of Operation .....	1
Installation Instructions	
Storage .....	2
Location .....	2
Piping - General .....	2
Suction Piping .....	2
Discharge Piping .....	3
Power Connections .....	4
Start-up Inspection .....	4
Pump Calibration .....	5
Maintenance Instructions	
Preventive Maintenance .....	6
Recommended Spare Parts .....	6
Oil Change .....	6
Check Valves .....	6
Diaphragm Replacement.....	7
Adjusting Internal Relief Valve .....	7
Replacing Control Valve O-Rings.....	8
Replacing Gear Shaft O-Rings.....	8
Series 1000 Specifications	
Bolt Torque Specifications.....	9
Special Tools Recommended for Repair/Maintenance .....	9
Spare Parts List	
Basic Drive Spare Parts List - Metallic Liquid End .....	10
Basic Drive Spare Parts List - Plastic Liquid End .....	11
Liquid End Spare Parts - Disc Diaphragm - Metallic .....	12
Liquid End Spare Parts - Disc Diaphragm - Plastic .....	13
Liquid End Spare Parts - Tubular Diaphragm - Metallic .....	14
Liquid End Spare Parts - Tubular Diaphragm - Plastic.....	15
Liquid End Spare Parts - Double Disc - Metallic.....	16
Liquid End Spare Parts - Double Disc - Plastic .....	17
Liquid End Spare Parts - Degassing Head.....	18
Installation Schematic - Degassing Head Pump .....	19
Pump Troubleshooting Chart .....	20
Spare Parts Ordering Instructions .....	back cover

## **Warranty**

Aquflow warrants its products against defects in workmanship or material under specified use and service for a period of 18 months from placement into service or 24 months from date of shipment. The obligation and liability of Aquflow is limited to repairing or replacing (at its option) such allegedly defective goods as are returned to Aquflow's plant. No liability is assumed for removal or reinstallation costs, warrants of merchantability or fitness for a particular purpose except as specified. Liability for consequential damages (including personal injury) is hereby excluded; liability in any event being limited to the original purchase price of the goods involved.

Defects shall not include decomposition by abrasion, chemical action, water, or caused by the presence of materials or conditions not specified. The component materials set forth in a proposal and/or the specifications of an order are recommended by Aquflow for the particular application. But such recommendations shall not be construed as warranty or guarantee against wear and/or corrosion, such recommendations are subject in all cases to verification and acceptance by purchaser. Any warranty on equipment and accessories furnished by outside manufacturers shall be limited to the warranty of the respective equipment and/or accessory manufacturer of such goods. When repairs or replacements are made under our warranty, all freight costs will be paid by the purchaser.

Aquflow will not be responsible for the work performed by others. Aquflow reserves the right to void applicable warranties if work by others is determined by Aquflow to be improperly executed or not required.

**Please read this instruction manual before installing pump.**

In this instruction manual, the **Note**, **CAUTION** and **WARNING** notations have the following meanings:

**Note:** This heading is used if a special feature or operating requirement is being pointed out.

**CAUTION:** This heading is used to denote when failure to follow the operating instructions as prescribed herein can lead to pump or system damage.

**WARNING:** This heading is used to denote when failure to follow the operating instructions as prescribed herein could result in **PERSONAL INJURY!**

## GENERAL DESCRIPTION

Series 1000 is a compact, reliable, industrial-duty positive displacement diaphragm metering pump, engineered to handle a wide range of chemicals and slurries.

Pump capacity is a function of drive speed, plunger diameter, and plunger stroke length. On the Series 1000 pump, the plunger stroke length is fixed. An adjustable hydraulic bypass system allows changing the effective stroke length from 0 to 100%, which in turn determines capacity of process fluid delivered on each stroke of the pump.

Capacity is easily adjustable while the pump is running or stopped, using the standard manual micrometer stroke control or optional electronic or pneumatic capacity controls.

## PRINCIPLE OF OPERATION

On the Series 1000, hydraulic oil is displaced by the plunger into the diaphragm head area, in which a PTFE disc diaphragm separates the oil from the process fluid. The alternating displacement of oil by the plunger causes the diaphragm to flex, thereby displacing an equal volume of process fluid on the other side of the diaphragm.

Process fluid flow through the diaphragm head is controlled by ball check valves. During the pump's suction stroke, the fluid is drawn into the liquid end; the suction check valve is open and the discharge

valve is closed. When the stroke is reversed, discharge occurs; the suction valve is closed and the discharge valve is open.

The check valves close at the end of the suction and discharge strokes by hydraulic differential pressure and from their own weight, since they are gravity assisted.

Normal hydraulic oil losses are continually replenished on each stroke of the plunger. This is accomplished by mechanically opening the displacement chamber to the oil-filled gearbox for a short period at the end of every suction stroke and at the beginning of each discharge stroke. During this time, air and/or vapor is bled from the system, lost oil is replenished, and allowances made for expansion or contraction of hydraulic oil due to temperature fluctuations.

An internal hydraulic relief valve protects the pump and drive from damage that could result from over-pressure due to discharge pipeline restrictions.

Pumping accuracy is within  $\pm 1\%$  of set point under constant conditions of viscosity, vapor pressure, temperature, discharge pressure and capacity setting.

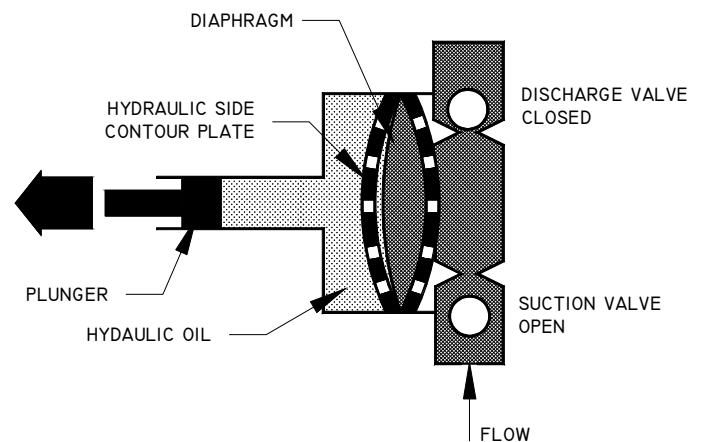

Figure 1. Suction Stroke

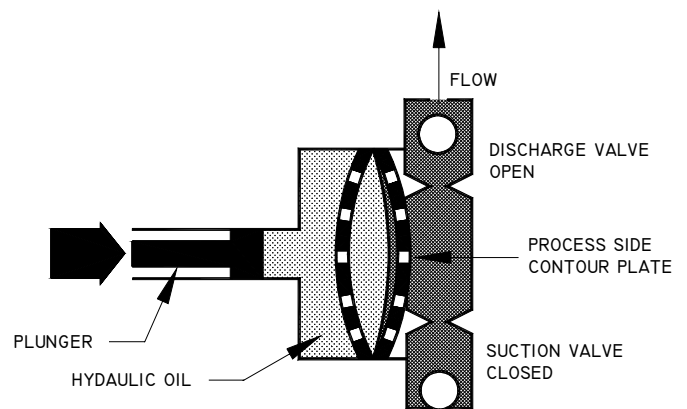

Figure 2. Discharge Stroke

## INSTALLATION INSTRUCTIONS

Prior to shipment, each pump is factory tested under application hydraulic conditions, using water. The internal relief valve is preset to meet the operating conditions specified on the purchase order, and the pump is fully assembled and ready for installation.

Protective caps are used to cover the suction and discharge check valves during shipment, and containers of hydraulic oil have been included in the shipping carton.

When unpacking the pump, make certain that no loose components are accidentally discarded. Examine the pump for shipping damage. If damage has occurred, a claim must be filed with the freight carrier within 24 hours.

## STORAGE

If the pump is not going to be installed immediately, but will be placed in storage for a period not to exceed 6 months, the following steps must be taken. Damage incurred as a result of improper storage protection will void the warranty.

1. Leave the pump in the original shipping carton and in an upright position, leaving all shipping plugs in place.
2. To protect critical internal components, make certain that pump is filled to capacity with hydraulic oil.
3. Store pump indoors or in a dry ambient controlled atmosphere to prevent temperature variations which may lead to condensation damage.
4. Contact the motor manufacturer for specific motor storage requirements.
5. Following storage, hydraulic oil must be changed prior to pump start-up.

**Note:** For storage in excess of 6 months, consult factory for long-term storage requirements.

## LOCATION

1. The pump installation site should provide easy access for capacity adjustment, routine maintenance, and where possible, to protect the pump from the elements and from leaks or drips from other process equipment.
2. The pump should be located on a level surface. While not required, it is suggested that the pump

be bolted on a concrete pad or slightly raised platform above floor level to protect pump from washdowns.

3. Pumps installed outdoors should be shaded from direct sunlight and protected from the elements. Direct sunshine and ambient temperatures above 90°F could cause excessive hydraulic oil and motor temperatures.

Installations with ambient temperatures outside 50-100°F require changing the oil to a different viscosity index to assure reliable performance. In extreme cold temperatures, insulation and heat tracing may be required.

## PIPING

1. The Aquflow® Series 1000 is a reciprocating motion type pump. Therefore, size the piping system to accommodate peak instantaneous flow which is 3.14 times pump capacity (example: 60gph x 3.14 = 188 gph). Failure to do so may restrict fluid flows, resulting in erratic pump performance.
2. Piping materials selected must be resistant to corrosion by the liquid being pumped, and rated to withstand maximum pressure and temperatures of the system.
3. When determining pipe size, be certain that it is equal to, or the next size larger than, the pump check valve connections.
4. When selecting fittings for use with flexible hose or tubing, be certain that the I.D. is equal to or larger than that of the tubing. Failure to do so may restrict fluid flows, resulting in erratic pump performance.
5. Use pipe sealant(s) sparingly. Excess sealant could dislodge and impede proper check valve operation. Be particularly careful when making pipe connections to plastic pump heads, since use of excessive sealant and/or overtightening may crack plastic pump heads.
6. Shut-off valves and unions installed in the suction and discharge pipelines will facilitate pump servicing.

## SUCTION PIPING

1. Before connecting the pump, **be certain that the suction piping is completely clean by flushing thoroughly.** Failure to do so may result in foreign matter entering and damaging the pump.

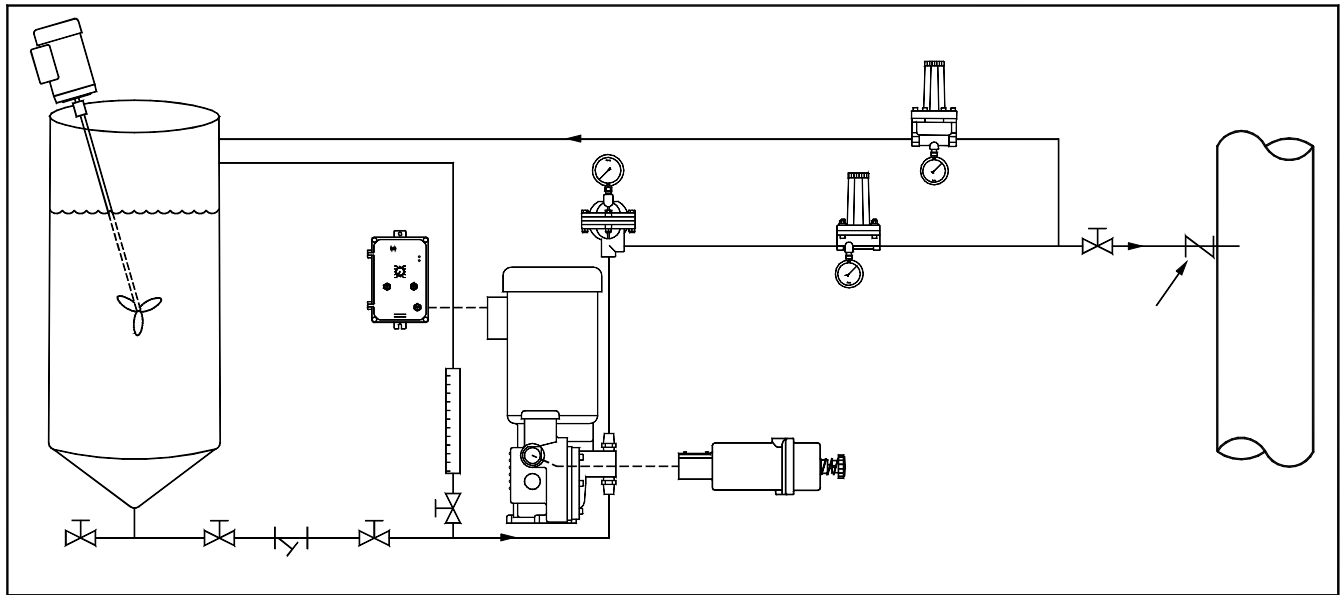

### 3. Typical Metering Pump Installation

2. Keep the suction line as short and straight as possible. A flooded suction or gravity feed of the process fluid to the pump inlet is preferred. **A suction line strainer is highly recommended** to prevent foreign matter from entering and damaging the pump.

**Note:** Suction lift applications require the use of a foot valve and strainer to prevent loss of prime and to prevent foreign material from entering the pump.

3. Suction piping must be absolutely airtight to assure accurate pumping. If air or gas is allowed to accumulate inside the pumphead, the output will become erratic or stop altogether.
4. Piping should be sloped to prevent the formation of vapor pockets, which could eventually accumulate inside the pumphead resulting in erratic pump delivery.
5. Do not spring the piping when mating it to the pump. Provide necessary pipe supports to avoid placing strain on the pump connections. Flexible connections can be used if pressure permits. If flexible suction line is used, be sure that selection and installation will prevent wall collapse and thus a starved suction condition.

6. Provision should be made in the system to avoid the possibility of running the pump dry. Typically this is accomplished by wiring a low-level shut-off switch mounted in the supply tank to the pump motor starter as shown in Figure 4.
7. Where pump fluids may solidify, crystallize, etc., provision should be made to flush the pump and piping regularly, especially prior to shutdown.

#### DISCHARGE PIPING

1. Install adequately sized pipe with a pressure rating in excess of the pressure relief valve setting.
2. A minimum positive pressure differential of 25 psi between the suction and discharge valves is recommended for proper hydraulic bypass operation and seating of the ball checks. Should normal discharge pressure be less than the suction pressure, an artificial discharge pressure must be created to prevent siphoning. This can be accomplished by the use of a back pressure valve installed in the discharge piping.
3. A properly sized pulsation dampener installed in the discharge pipeline between the pump and back pressure valve will smooth out flow peaks, reduce "water hammer" and protect downstream instrumentation.

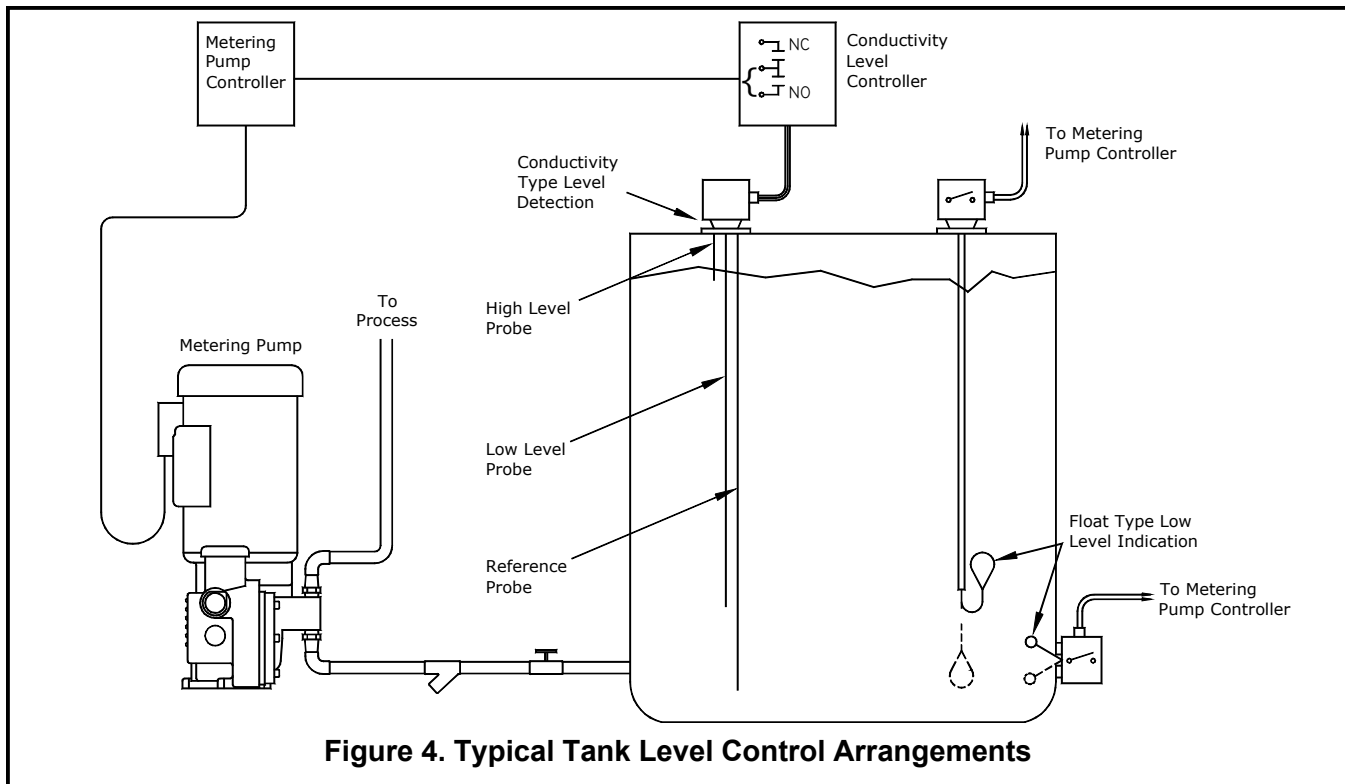

**Figure 4. Typical Tank Level Control Arrangements**

- For additional safety, a Hydrolnjet™ Assembly should be installed at the point where the discharge line enters a boiler, other high-pressure process vessel or any pressurized system.

**CAUTION:** The internal relief valve is designed only to protect the pump and drive components in the event the piping system is restricted or blocked while the pump is in operation.

If there are other sources of pressure or hydraulically isolated sections of piping in the system, an external safety relief valve must be installed in the pump discharge line as close to the pump as possible, and BEFORE any isolation valve. The safety relief valve should be piped back to the suction tank or safety drain as shown in Figure 3.

## POWER CONNECTIONS

- Check the nameplate rating of the motor and any auxiliary electrical equipment against the available power supply before making connections. Direction of rotation of the motor is important, and must be clockwise when viewing the motor from the top. Jog the motor to check rotation.

- Standard wiring and conduit piping practice in accordance with local electrical codes should be followed. A motor starter with properly sized thermal overload heater is recommended.
- Provide adequate ventilation for the drive motor.

**CAUTION:** Motor starters with properly sized thermal overload are recommended for motor protection. These are typically supplied by others!

**Note:** Motors are warranted by the motor manufacturer. You can obtain prompt local service by consulting the motor manufacturer's authorized service station nearest you, as listed on the Internet or in the yellow pages. NPA can also assist you in locating this information.

Please do not return motors directly to NPA, as this will only delay warranty service.

## START-UP INSPECTION

Several items should be checked after the pump has been installed and prior to initial start-up.

- Series 1000 pumps are shipped with hydraulic oil supplied separately in 1-quart containers.



**Note:** The oil shipped with the pump is for the typical application - operation at ambient temperatures from 50-100°F.

Remove the reservoir cover and slowly pour in the hydraulic oil until it reaches the level mark shown on the pump housing.

2. After initial filling, run the pump for 15 minutes with micrometer knob set at 0% to allow hydraulic oil to completely fill all pump cavities, then recheck level and add oil as necessary. Smaller plunger size pumps may require longer running at 0% micrometer setting to fully vent entrained air from the hydraulic oil.
3. Check to be certain that the electrical supply matches the pump nameplate electrical characteristics.
4. Check to be certain that accessory components and fittings have been installed in the proper orientation and sequence as shown in Figure 3.
5. Jog motor to assure proper clockwise rotation.
6. Make certain that suction and discharge valves are open prior to pump start-up.
7. It is important that pump suction and discharge lines are free of entrained air. To assure proper start-up, start the pump without any discharge pressure (vented to atmosphere) and with the micrometer set at 0% capacity. Slowly turn the micrometer towards 100% capacity to fill the pumping system with process fluid.

**Note:** On suction lift applications, it may be necessary to prime the pump by first wetting the ball check valves, and starting the pump without any discharge pressure (vented to atmosphere). Suction lift applications require the use of a foot valve strainer to prevent loss of prime.

## PUMP CALIBRATION

Each pump is tested at the factory prior to shipment to assure proper operation at the capacity and discharge pressure specified. For precise capacity control in the field, a calibration test under actual pumping and piping conditions is recommended.

This can be accomplished by allowing the pump to operate at full capacity for a minimum of 30 minutes. This will clear any air out of the pump.

Pump calibration can be accomplished by measuring the decrease in liquid level pumped from a HydroChek™ calibration column installed in the suction line as shown in Figure 3 on page 3. Follow the calibration instructions provided by the cylinder manufacturer.

An alternate method of calibration for non-hazardous applications is to collect and measure the fluid metered from the pump discharge port into a graduated cylinder or tank.

Typically, test samples are collected at 25%, 50%, 75% and 100% capacity settings. A straight line results when these points are plotted on a graph. This graph can then be used for intermediate settings, assuming suction and discharge conditions remain constant.

**WARNING:** Use extreme care when performing calibration test using open cylinder or tank method, and be extremely careful when working in the presence of hazardous substances.

***Wear suitable protective clothing and eye shielding for protection.***

It is important to realize that the samples at 50% will not necessarily be exactly 1/2 of that at 100%, nor will any other sample points be a specific percentage of the 100% value. But, the sample value will lie along a straight line that can be used for intermediate settings, and the pump will give repetitive samples at the same setting. This last characteristic is what makes the NIKKISO Hydroflo® Series 1000 pump effective; it will meter chemicals precisely within  $\pm 1\%$  of capacity set point over long periods of time.

Also, as operating discharge pressures increase, there are additional hydraulic system losses which are constant for any given discharge pressure.

This results in a small decrease in the maximum capacity output of the pump. All Hydroflo® capacity/pressure charts used for pump selection have a base pressure rating of 100 psig. For higher discharge pressure decrease maximum capacity by 1.25% for every 100 psig increase.

## MAINTENANCE INSTRUCTIONS

**WARNING:** Disconnect and lockout power to the pump before performing service or disassembling the pump.

### PREVENTATIVE MAINTENANCE

The Series 1000 metering pump is designed for continuous service with maximum reliability and minimum downtime. However, good maintenance procedures dictate that certain visual periodic checks be made to assure that operating problems have not developed.

1. Check the hydraulic oil level periodically, to be sure it is at the proper level mark, and adjust as necessary.
2. Inspect the liquid end assembly, including the suction and discharge connections for any indication of leakage, and correct as necessary.
3. Hydraulic oil should be replaced once a year following the procedures outlined under "Oil Change."

### RECOMMENDED SPARE PARTS

To minimize downtime, the following spare parts should be inventoried to support each pump. These spare parts are available in vacuum-sealed packaging, which provides infinite shelf life when properly stored.

- (1) Diaphragm
- (1) Diaphragm O-Ring
- (1) Motor O-Ring
- (2) Check Valve Balls\*
- (2) Check Valve Seats\*
- (1) Control Spool Snap Ring<sup>a</sup>
- (1) Control Spool Wave Washer<sup>a</sup>
- (1)<sup>b</sup> Control Spool Plunger<sup>a</sup>
- (1) Control Spool Spring<sup>a</sup>
- (1) Control Spool Retaining Pin<sup>a</sup>
- (3)<sup>b</sup> Control Spool O-Rings
- (2) Drive Housing Gear Shaft O-Rings
- (1) Change of Drive Lubricant

#### Notes:

1. Multiplex pumps require one (1) Spare Parts Pak for each liquid end.
2. \*3/8" Check Valves are supplied as complete assemblies.
3. <sup>a</sup> Model specific parts, only included if required.
4. <sup>b</sup> Quantity varies by Model.

**Note:** Multiplex pumps require one (1) Spare Parts Pak for each liquid end.

### OIL CHANGE

1. Under normal operating conditions the hydraulic oil should be drained and replaced once a year. In severe applications the hydraulic oil should be changed more frequently.
2. Drain hydraulic oil using the drain plug on the side of the pump. (For convenience the drain plug can be replaced with a quick draw fitting or valve and short nipple.)

The recommended lubricant for NIKKISO Hydroflo<sup>®</sup> Series 1000 is Zurn E.P. #95, for normal operation. Various manufacturers' equivalent oils are listed below:

(Indoor, temperature controlled ambient)

ZURN	EP Lube #EP95
Amoco	Permagear #220
Drydene	E.P. Gear Oil #5
Exxon	Spartan #EP220
Mobil	Mobilgear #630
Shell	Omala #220
Texaco	Meropa #220

For applications with different ambient or fluid temperatures, please consult factory for alternate lubricant recommendations.

### CHECK VALVES

1. Aquflow<sup>®</sup> check valve assemblies utilize oversized balls and are designed to be self-cleaning, and should seldom need service.
2. Fouled metallic check valves can usually be cleaned in a mild solvent solution, followed by a clean water flush. Blow check valve assembly dry using clean compressed air. The check valve ball should be free falling within the valve body.
3. Plastic check valves must be disassembled to facilitate cleaning. It is recommended that new o-rings be installed during reassembly.
4. Repair or replace any check valve components that exhibit damage or wear from chemical corrosion. Ball check valves can be tested for proper sealing by filling ball/seat area with water. For the check valve to be usable it must hold a five foot column of water for 30 seconds without leaking.

## DIAPHRAGM REPLACEMENT

Except in the unlikely event of a loss in integrity, the diaphragm does not require replacement. Should a diaphragm replacement be required, the following steps must be followed:

### DISASSEMBLY

1. Wear suitable protective clothing and eye shielding for protection.
2. Disconnect and lockout electrical power to the pump and drain hydraulic oil.
3. Isolate and disconnect the piping from the suction and discharge check valves.
4. Flush process fluid from liquid end, using a suitable neutralizing agent.
5. Remove the bolts from the liquid end and remove it from the drive housing. Note the orientation of the check valve cartridges prior to removing the diaphragm head, as they must be in the same position when diaphragm head is reassembled.
6. Remove diaphragm, contour plate and support plate; inspect for any obvious damage.

**Note:** To prevent leakage, never attempt to reuse the old diaphragm.

### REASSEMBLY

1. Set the stroke length control to 100%.
2. Set the diaphragm backing plate (7508) in the diaphragm cavity within the pump drive housing (7501).
3. Place the diaphragm o-ring (7510) in its groove within the diaphragm cavity.
4. Place the new diaphragm (2631) over the diaphragm o-ring centering the diaphragm in its cavity. Depress the center of the diaphragm to create a vacuum (suction) to hold the diaphragm in place.
5. Place the diaphragm head assembly over the bolt holes. Care must be taken to prevent the diaphragm from moving out of place. Retain this assembly in place using the six head bolts (4305 on metallic head) (2908 on plastic head).
6. Tighten the head bolts in steps using a diagonal and clockwise pattern to a final torque value described in the "Specification section."

7. Replace the drain plug and refill the pump with the appropriate hydraulic oil as described under the "Oil Change."
8. Reconnect the suction and discharge lines.
9. Follow the "Start Up Inspection" procedure as outlined earlier. Run the pump and check for leaks.
10. Return the pump to service.

## ADJUSTING INTERNAL RELIEF VALVE

The internal relief valve is factory set to open at a pressure slightly higher than the discharge pressure indicated on the pump dataplate. Unless otherwise indicated, when the pump is ordered the internal relief valve is set to open at the greater of 20 psig or 20% above the discharge pressure.

1. Wear suitable protective clothing and eye protection.
2. Install a pressure gauge in the discharge line of the metering pump with a range 50% greater than the desired internal relief valve setting.
3. Install a adjustable safety relief valve downstream from the pressure gauge.
4. Remove the oil reservoir cap assembly (2618). The brass internal relief adjuster (2615) is located on a cast-in boss just under the cover. The adjuster requires a 5/16" hexagonal type "Allen" wrench.

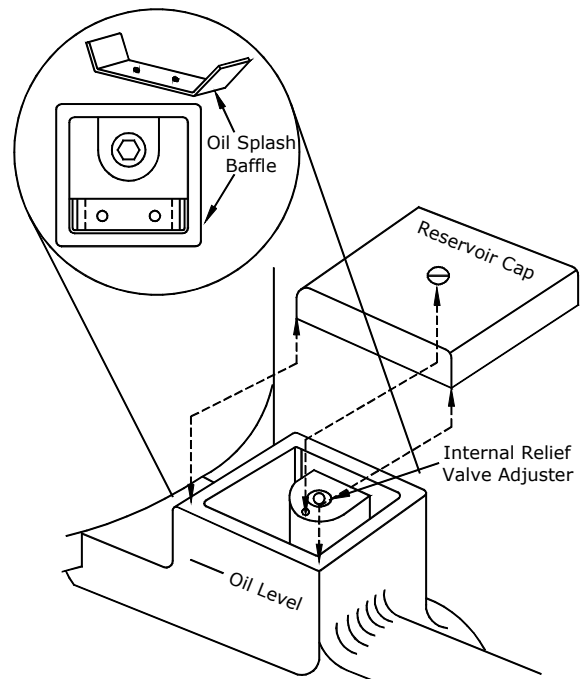

**Figure 5. Relief Valve & Oil Fill Port**

5. Set the capacity adjuster to 100%, back off the adjustment to the safety relief valve so it opens at zero psig and start the pump. Continue to run the pump long enough to establish good pumping action.
6. Increase the seating of the SRV until the pump starts to build pressure. Carefully and continually observe the pressure indicated on the gauge. Gradually increase the safety relief valve setting until the pump internal relief valve actuates.
7. Rotate the internal relief valve adjuster CCW to decrease the pressure and CW to increase the pressure. Adjustments should be made in 1/4 turn increments. After each adjustment, relieve the discharge pressure by opening the safety relief valve. Observe the pressure gauge and repeat the adjustment as described until the desired internal relief valve pressure is indicated on the pressure gauge.
8. After adjustments are complete, return the safety relief valve to its appropriate setting.
9. Return pump to service.

**WARNING:** Do not run pump with relief valve adjuster "bottomed out," as severe damage to pump may result!

*Never exceed pressure rating of pump or any component of the system or piping!*

*When the relief valve is actuated, particularly in the larger plunger size or high-speed units, oil may be ejected at high velocity through the bypass port. Routine precautions should be taken to prevent oil from splashing the operator of the surrounding area!*

## REPLACING CONTROL VALVE O-RINGS

Control spool o-rings are included in the spare parts pak, and they can be easily replaced during routine pump maintenance.

1. Disconnect and lockout electrical power to the pump and drain hydraulic oil.
2. Remove the (2) bolts (7504) holding the motor and remove motor from pump.
3. Remove the (2) actuator screws (2629), and slide the actuator (2610) off the bypass tube (Note the orientation of actuator before removal).
4. Remove the control valve screw (2641) from housing (The screw at front of capacity plate).

5. Turn control valve counterclockwise until fully released.
6. Pull the control valve from pump housing.
7. Replace the (3) control valve o-rings (2623).
8. Remove control spool from micrometer knob by using snap ring pliers to remove the snap ring (2628).
9. Replace spring washer (2636).
10. Insert the control spool into the micrometer knob and retain in place using the new snap ring.
11. Apply a thin film of hydraulic oil to the control spool o-rings and carefully slide assembly back into pump housing. The bypass tube should be in the control spool and left extended about 1.5".
12. Thread the control spool to 100% capacity setting.
13. Reinstall the retaining screw (2641) in housing.
14. Replace actuator (2610) in the correct orientation and reinstall screws (2629).
15. Replace the motor, then refill housing with hydraulic oil to proper level.
16. Restart pump.

## REPLACING GEAR SHAFT O-RINGS

1. Disconnect and lockout electrical power to the pump (Note: If this procedure is done carefully, it may not be necessary to drain hydraulic oil).
2. Remove the (2) gearshaft screws (2643) from the housing - one on each side of the housing.
3. Slide gear shaft approximately 1/2" in either direction; DO NOT REMOVE IT FULLY.
4. Remove and replace exposed o-ring (2642).
5. Apply a thin film of oil to the o-ring and slide gear shaft back into housing. Replace opposite side o-ring using the same procedure.
6. Slide gear shaft to its original position and reinstall (2) retaining screws (2643), using Loctite® part no. 24241 or equal.
7. Recheck the hydraulic oil level and add oil as necessary.
8. Restart pump.

## Series 1000 Specifications

Capacity range at 100% stroke setting <sup>1</sup>	0.55 to 61.8 GPH		
Maximum allowable discharge pressure <sup>2</sup>	DISC	TUBE	PLASTIC
3/8" plunger	5000 PSIG	400 PSIG	300 PSIG
9/16" plunger	1100 PSIG	400 PSIG	300 PSIG
3/4" plunger	1100 PSIG	400 PSIG	300 PSIG
7/8" plunger	700 PSIG	400 PSIG	300 PSIG
1-1/8" plunger	425 PSIG	400 PSIG	300 PSIG
1-5/8" plunger	200 PSIG	200 PSIG	200 PSIG
Capacity adjustment	0 to 100% while running or stopped		
Turndown ratio			
Stroke length	10:1		
Stroke frequency	10:1		
Maximum combination	100:1		
Metering accuracy			
Steady state	±1% of maximum capacity		
Linearity	±1% of maximum capacity		
Repeatability	±1% of maximum capacity		
Maximum process fluid temperature			
custom engineered metallic liquid end	500°F (260°C)		
metallic liquid end/PTFE diaphragm	250°F (121°C)		
plastic head	140°F (60°C)		
Plunger stroke length	3/4"		
Hydraulic oil capacity			
Simplex	2 quarts (approx.)		
Duplex	3 quarts (approx.)		
Displacement per stroke			
3/8" plunger	0.0828 in <sup>3</sup> (1.35 ml)		
9/16" plunger	0.1864 in <sup>3</sup> (3.50 ml)		
3/4" plunger	0.3313 in <sup>3</sup> (5.43 ml)		
7/8" plunger	0.4510 in <sup>3</sup> (7.40 ml)		
1-1/8" plunger	0.7872 in <sup>3</sup> (12.9 ml)		
1-5/8" plunger	1.51 in <sup>3</sup> (24.71 ml)		
Recommended suction strainer size	up to 7/8" plunger - 80 mesh screen (.007 openings) 1-1/8" & 1-5/8" plunger - .033 diameter (1/32") perforations		
Notes:			
1. Simplex capacities shown - double capacities for duplex pump.			
2. Maximum allowable discharge pressures require motor of proper horsepower.			

<b>Bolt Torque Specifications</b>		
	<b>Metallic Diaphragm Head</b>	<b>Plastic Diaphragm Head</b>
Head Bolts	130-150 in-lbs.	45 in-lbs.
Check valves	150-190 in-lbs.	N/A
Motor Bolts	100 in-lbs.	

### Tools which are helpful in maintaining/servicing the Series 1000 pump:

- Torque wrench with 0-200 in/lb. operating range.
- 3/16" Allen wrench to remove metallic diaphragm head bolts.
- 5/16" Allen wrench to adjust internal relief valve.
- #2 Phillips screwdriver and large slotted screwdriver.

## Basic Drive Spare Parts - Cross Section

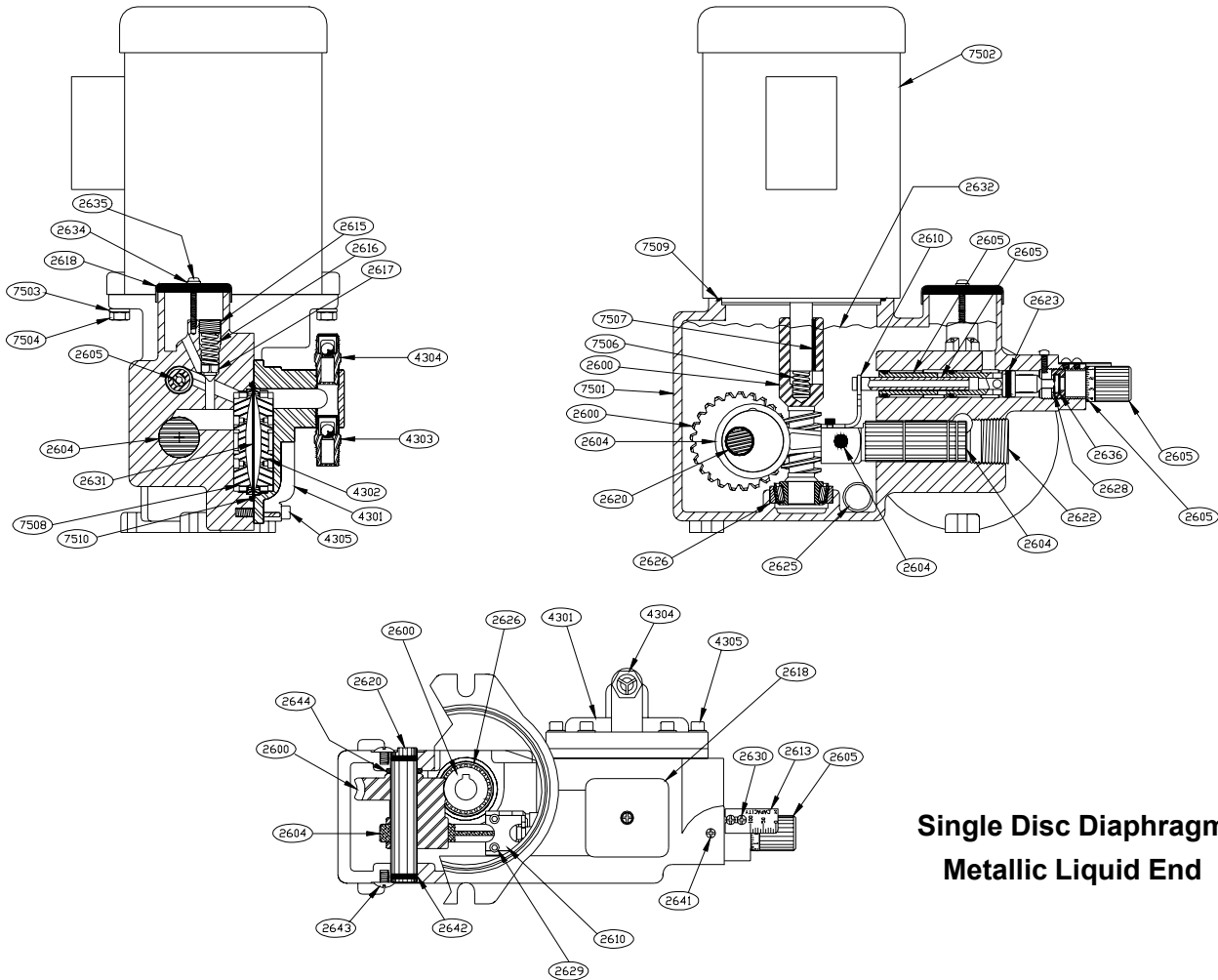

**Single Disc Diaphragm  
Metallic Liquid End**

Item	Qty.	Description	Item	Qty.	Description	Item	Qty.	Description
2600	1	Set, Simplex Gear	2630	2	Screw, Capacity Plate	4302	1	Plate, Contour
2601	1	Set, Duplex Gear (not shown)	2631	1	Diaphragm	4303	1	Ass'y, Check Valve Suction
2604	1	Ass'y, Plunger Crosshead	2632	2-3	Oil, Hydraulic; Quart	4304	1	Ass'y, Check Valve Discharge
2605	1	Assembly, Control Valve	2633	1	Baffle (not shown)	4305	6-8	Bolt, Liquid End
2610	1	Actuator, Bypass	2634	1	Washer, Reservoir Cover	7501	1	Housing, Drive
2613	1	Plate, Capacity	2635	1	Screw, Reservoir Cover	7502	1	Motor
2615	1	Adjuster, Hyd. Relief Valve	2636	1	Washer, Spring Control Valve	7503	2	Washer, Motor Mounting
2616	1	Spring, Hyd. Relief Valve	2640	1	Base (optional-not shown)	7504	2	Bolt, Motor Mounting
2617	1	Poppet, Hyd. Relief Valve	2641	1	Screw, Control Valve	7506	1	Spring, Worm Shaft
2618	1	Assembly, Reservoir Cover	2642	2	O-Ring, Gearshaft	7507	1	Key, Motor to Worm Shaft
2620	1	Shaft, Gear	2643	2	Screw, Gearshaft	7508	1	Plate, Diaphragm Backing
2621	1	Wristpin	2644	1	Spacer, Gear, Simplex	7509	1	O-Ring, Motor Sealing
2622	1	Plug, Plunger Bore	2645	1	O-Ring, 1-5/8 Plunger Bore	7510	1	O-Ring, Diaphragm
2623	3	O-Ring, Control Valve	2646	2	Screw, 1-5/8 Plunger Bore	7511	1	Plate, Metric Motor Adaptor (not shown)
2625	1	Plug, Oil Drain			Plug (N/A - not shown)	7515	3	Bolts, Drive Housing to Base (not shown)
2626	1	Bearing, Worm Shaft	4301	1	Liquid End			
2628	1	Ring, Snap, Control Valve						
2629	2	Screw, Actuator						

\* Most items vary in size, configuration and materials of construction by pump model number. Pump model and serial numbers are required to order replacement parts.

## Basic Drive Spare Parts - Cross Section

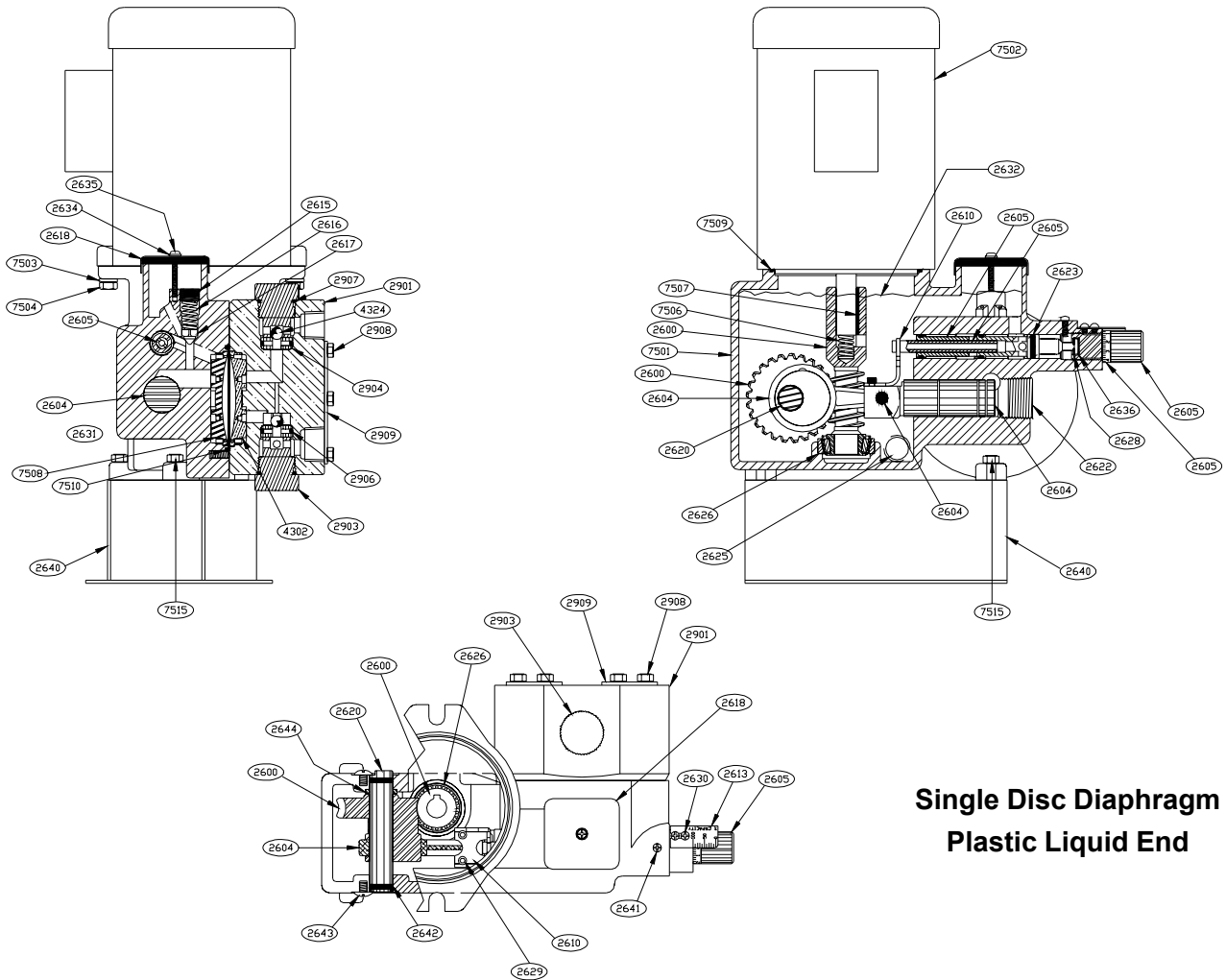

**Single Disc Diaphragm  
Plastic Liquid End**

Item	Qty.	Description	Item	Qty.	Description	Item	Qty.	Description
2600	1	Set, Simplex Gear	2631	1	Diaphragm	2906	2	O-Ring, Check Valve Seat
2601	1	Set, Duplex Gear (not shown)	2632	2-3	Oil, Hydraulic; Quart	2907	2	O-Ring, Check Valve Cap
2604	1	Ass'y, Plunger Crosshead	2633	1	Baffle (not shown)	2908	6	Bolt, Liquid End
2605	1	Assembly, Control Valve	2634	1	Washer, Reservoir Cover	2909	2	Plate, Liquid End Bolting
2610	1	Actuator, Bypass	2635	1	Screw, Reservoir Cover	4302	1	Plate, Contour
2613	1	Plate, Capacity	2636	1	Washer, Spring, Control Valve	4324	2	Ball, Check Valve
2615	1	Adjuster, Hyd. Relief Valve	2640	1	Base	7501	1	Housing, Drive
2616	1	Spring, Hyd. Relief Valve	2641	1	Screw, Control Valve	7502	1	Motor
2617	1	Poppet, Hyd. Relief Valve	2642	2	O-Ring, Gearshaft	7503	2	Washer, Motor Mounting
2618	1	Assembly, Reservoir Cover	2643	2	Screw, Gearshaft	7504	2	Bolt, Motor Mounting
2620	1	Shaft, Gear	2644	1	Spacer, Gear, Simplex	7506	1	Spring, Worm Shaft
2621	1	Wrist Pin	2645	1	O-Ring, 1-5/8" Plunger Bore	7507	1	Key, Motor to Worm Shaft
2622	1	Plug, Plunger Bore	2646	2	Screw, 1-5/8" Plunger Bore	7508	1	Plate, Diaphragm Backing
2623	3	O-Ring, Control Valve			Plug (N/A - not shown)	7509	1	O-Ring, Motor Sealing
2625	1	Plug, Oil Drain			Plug (N/A - not shown)	7510	1	O-Ring, Diaphragm
2626	1	Bearing, Worm Shaft	2901	1	Head, Diaphragm	7511	1	Plate, Metric Motor Adaptor (not shown)
2628	1	Ring, Snap, Control Valve	2903	2	Cap, Check Valve			
2629	2	Screw, Actuator	2904	2	Seat, Check Valve			
2630	2	Screw, Capacity Plate				7515	3	Bolts, Drive Housing to Base

\* Most items vary in size, configuration and materials of construction by pump model number. Pump model and serial numbers are required to order replacement parts.

## Liquid End Spare Parts - Disc Diaphragm - Metallic

ITEM	DESCRIPTION	QTY
2631	DIAPHRAGM	1
2901	LIQUID END	1
4302	PLATE, CONTOUR	1
4303	ASSY, SUCTION CHECK VALVE	1
4304	ASSY, DISCHARGE CHECK VALVE	1
4305	BOLT, HEAD	6-8
7508	PLATE, BACKUP	1
7510	O-RING, DIAPHRAGM	1

### SINGLE DISC DIAPHRAGM METALLIC LIQUID END

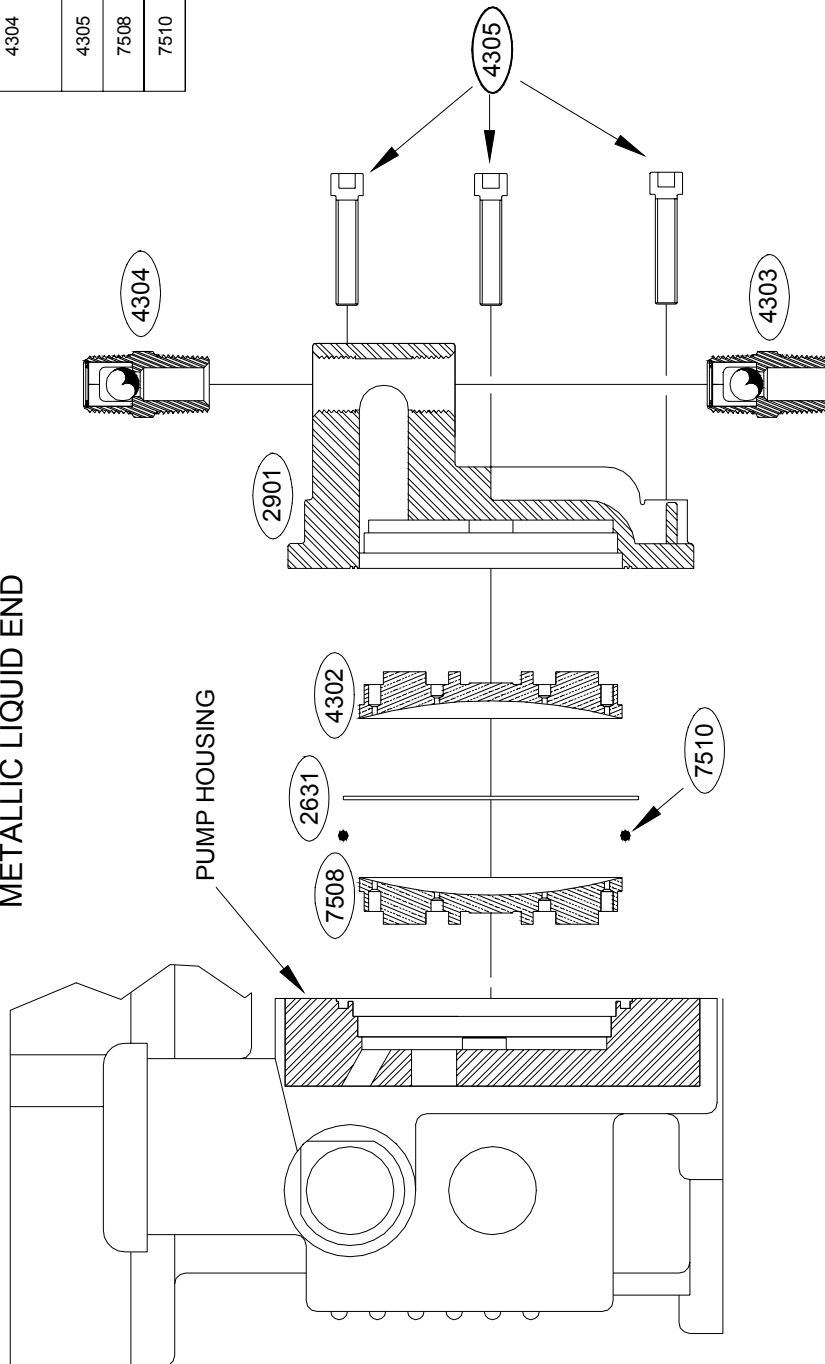



# Liquid End Spare Parts - Disc Diaphragm - Plastic

ITEM	DESCRIPTION	QTY
2631	DIAPHRAGM	1
2901	LIQUID END	1
2903	CAP, CHECK VALVE	2
2904	SEAT, CHECK VALVE	2
2906	O-RING, CHECK VALVE SEAT	2
2907	O-RING, CHECK VALVE CAP	2
2908	BOLT, LIQUID END	6
2909	PLATE, LIQUID END BOLTING	2
4302	PLATE, CONTOUR	1
4324	BALL, CHECK VALVE	2
7508	PLATE, BACKUP	1
7510	O-RING, DIAPHRAGM	1

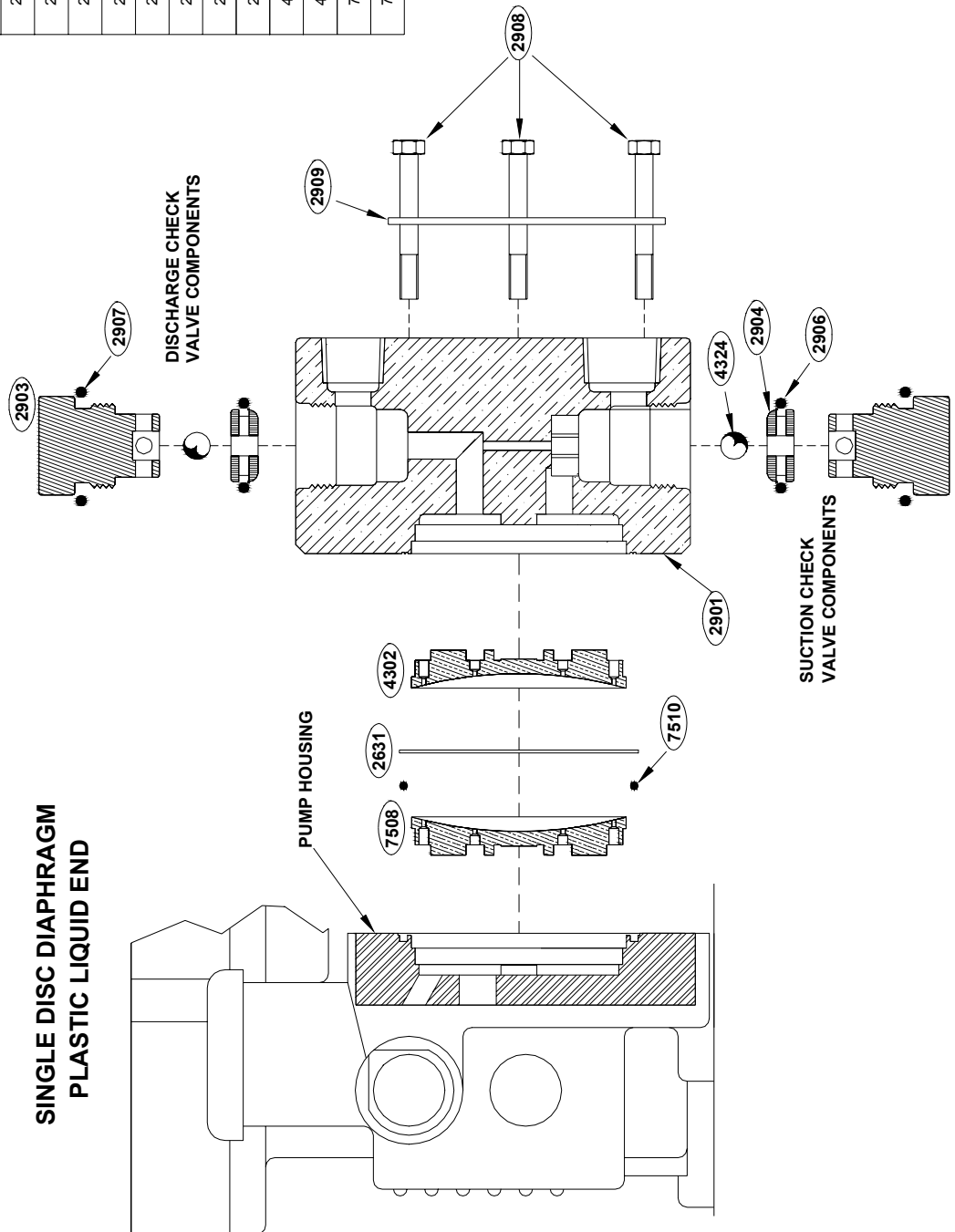

## Liquid End Spare Parts - Tubular Diaphragm - Metallic

### TUBULAR/DISC DOUBLE DIAPHRAGM METALLIC LIQUID END

ITEM	DESCRIPTION	QTY
2912	VALVE, BLEED	1
2913	VALVE, FILL INTERMEDIATE (SCHRADER TYPE)	1
4303	ASSY, SUCTION CHECK VALVE	1
4304	ASSY, DISCHARGE CHECK VALVE	1
8901	PLATE, MOUNTING	1
8902	PLATE, ADAPTOR	1
8903	HOUSING, TUBULAR DIAPHRAGM	1
8904	O-RING, HOUSING - PLATE SEAL	1
8905	DIAPHRAGM, TUBULAR	1
8906	FLANGE, TUBE	2
8910	BOLT, MOUNTING PLATE	3
8911	BOLT, TUBE HOUSING (SHORT)	4
8912	BOLT, ADAPTOR PLATE	6
8913	O-RING, ADAPTOR - MOUNTING SEAL	1
8914	BOLT, TUBE FLANGE	4
8915	BOLT, TUBE HOUSING (LONG)	4

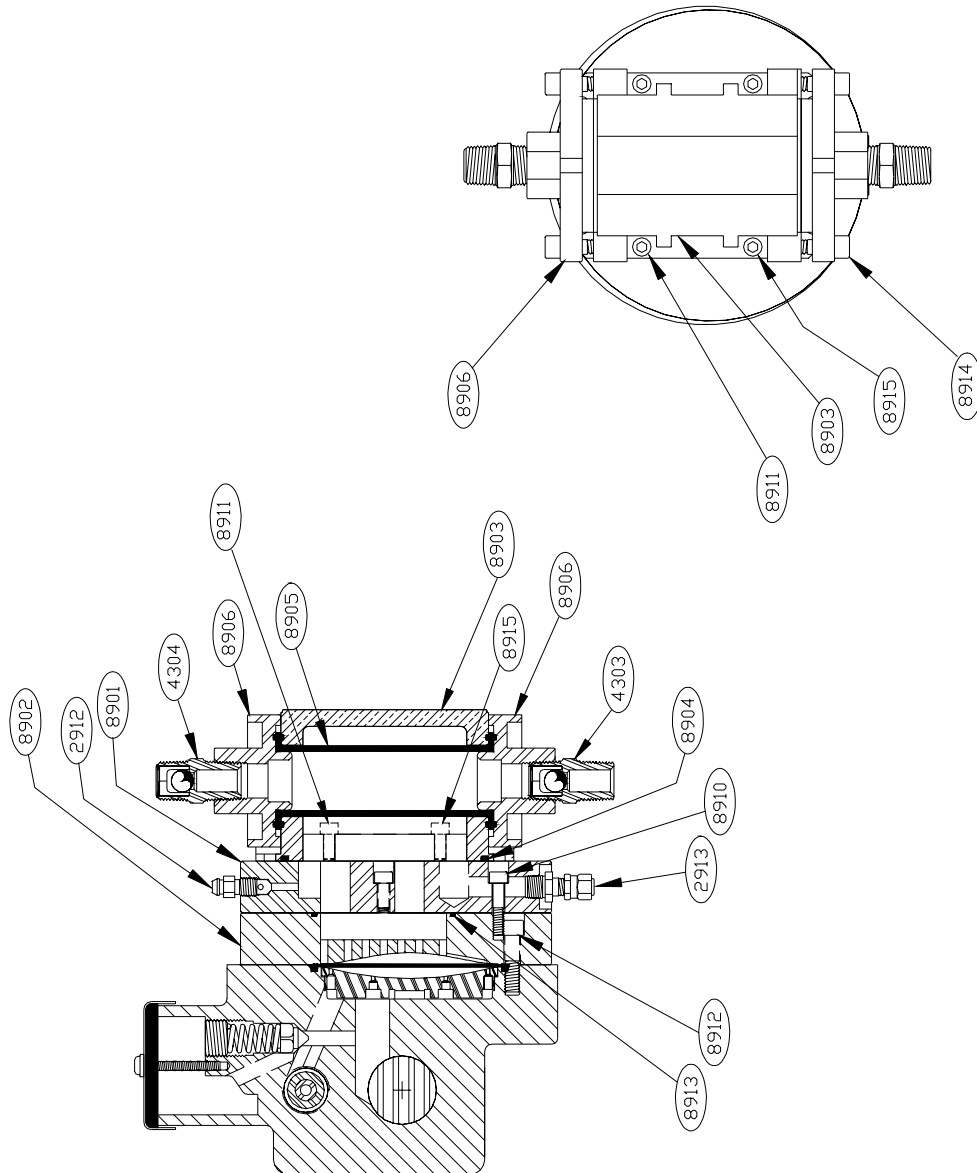

## Liquid End Spare Parts - Tubular Diaphragm - Plastic

### TUBULAR/DISC DOUBLE DIAPHRAGM PLASTIC LIQUID END

ITEM	DESCRIPTION	QTY
4323	GUIDE, BALL	2
4324	BALL, CHECK VALVE	2
8903	HOUSING, TUBULAR DIAPHRAGM	1
8905	DIAPHRAGM, TUBULAR	1
8906	FLANGE, TUBE	2
8923	SEAT, CHECK VALVE	2
8924	ACTUATOR BRACKET	2
8925	YOKE, CHECK VALVE	2
8928	O-RING, CHECK VALVE SEAT	4
8929	WASHER, LOCK	4
8930	NUT	8
8931	STUD	4
8932	PLATE, FLANGE	2

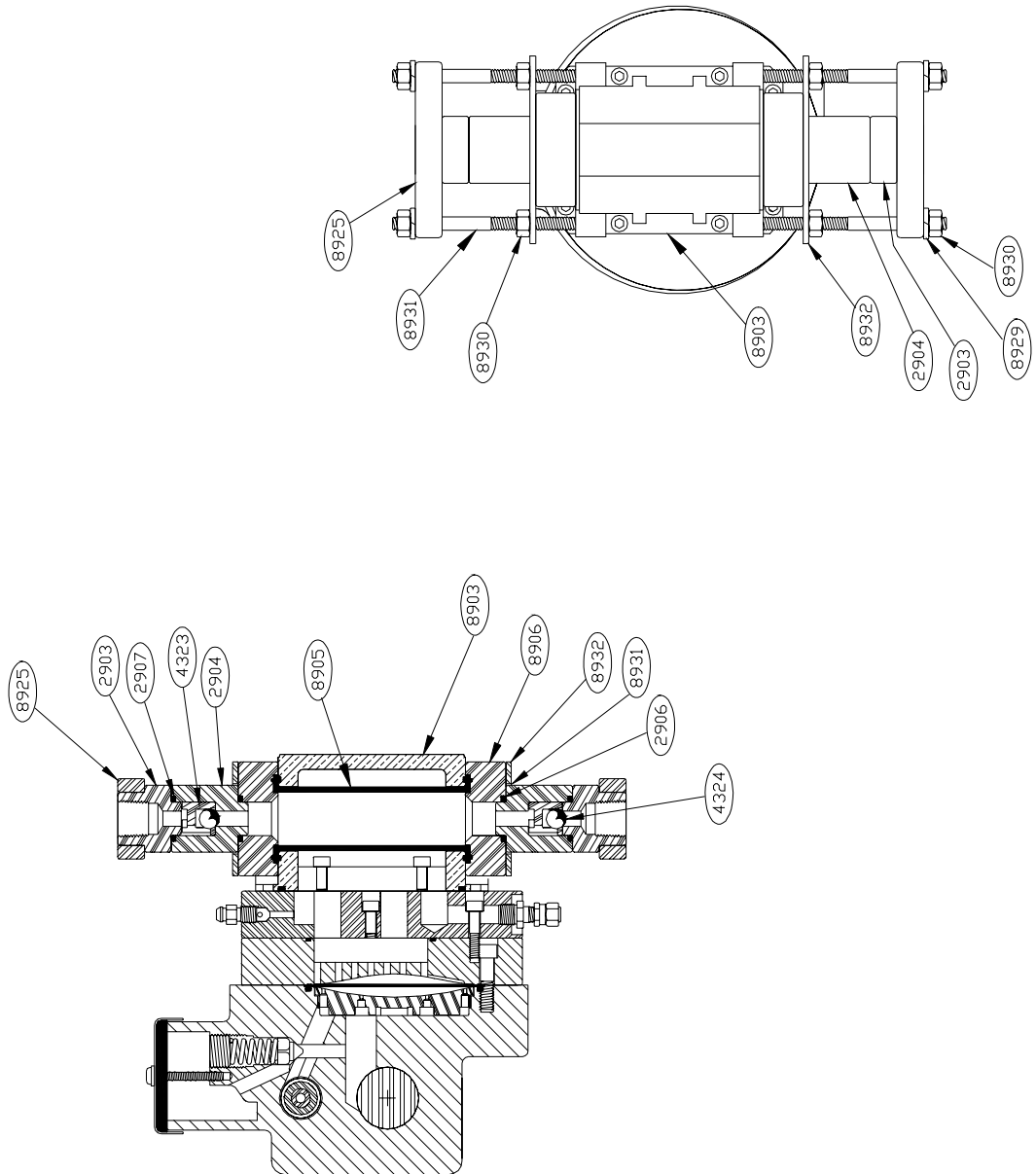

## Liquid End Spare Parts - Double Disc - Metallic

### DOUBLE DISC DIAPHRAGM PUMP HEAD METALLIC LIQUID END

ITEM	DESCRIPTION	QTY
2631	DIAPHRAGM	2
2911	INTERMEDIATE CHAMBER	1
2912	BLEED VALVE	1
2913	SCHRADER VALVE	1
4301	HEAD, DIAPHRAGM	1
4302	PLATE, CONTOUR	1
4303	ASSY, SUCTION CHECK VALVE	1
4304	ASSY, DISCHARGE CHECK VALVE	1
4305	HEX HEAD CAP SCREW, HEAD	6
7508	PLATE, DIAPHRAGM BACKING	1
7510	O-RING, DIAPHRAGM	1

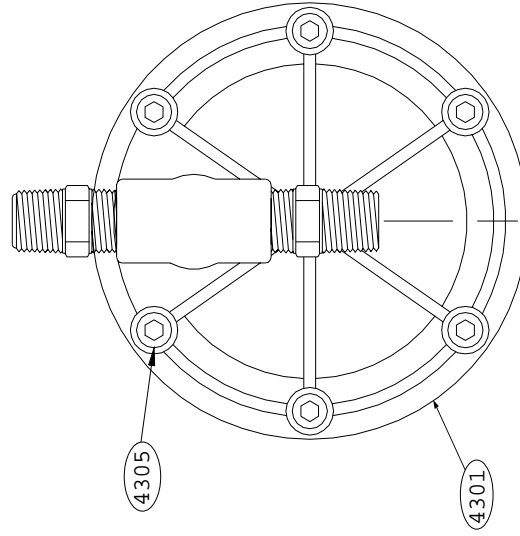
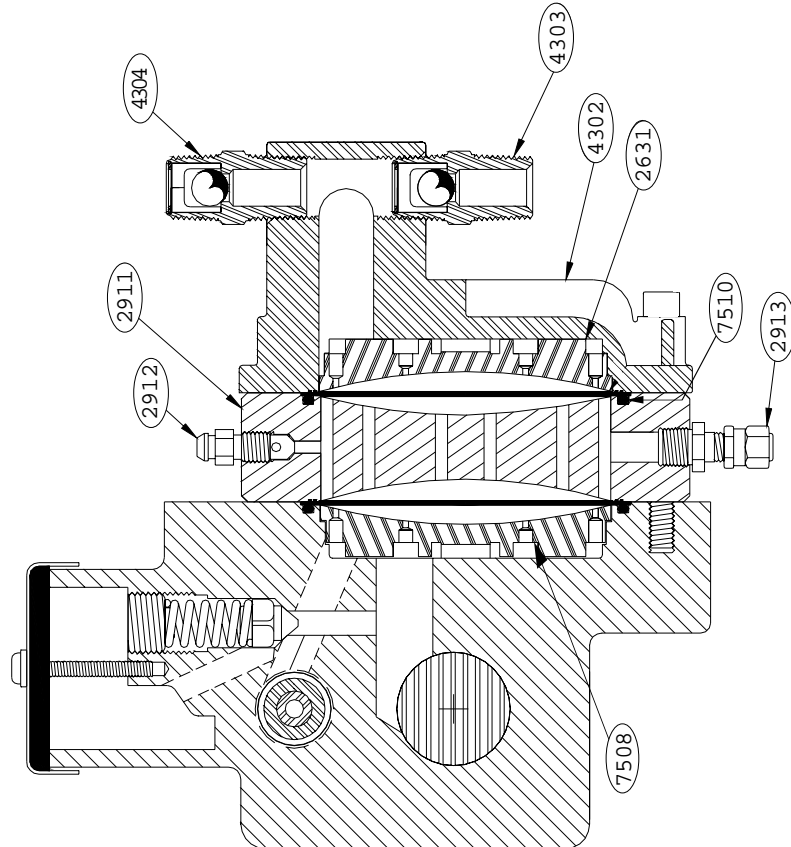

Liquid End Spare Parts - Double Disc - Plastic

**DOUBLE DISC DIAPHRAGM PUMP HEAD  
PLASTIC LIQUID END**

The following spare parts cover plastic check valve components only. Refer to the previous page for the common liquid end components.

ITEM	DESCRIPTION	QTY
2901	DIAPHRAGM HEAD	1
2902	PLATE, CONTOUR	1
2903	CAP, CHECK VALVE	2
2904	SEAT, CHECK VALVE	2
2905	BALL, CHECK VALVE	2
2906	O-RING, SEAT	2
2907	O-RING, CAP	2
2908	BOLTING PLATE	2
2909	BOLT, DIAPHRAGM HEAD	6
2910	DIAPHRAGM	1
2911	INTERMEDIATE CHAMBER	1
2912	VALVE, BLEED	1
2913	VALVE, FILL INTERMEDIATE (SCHRADER TYPE)	1

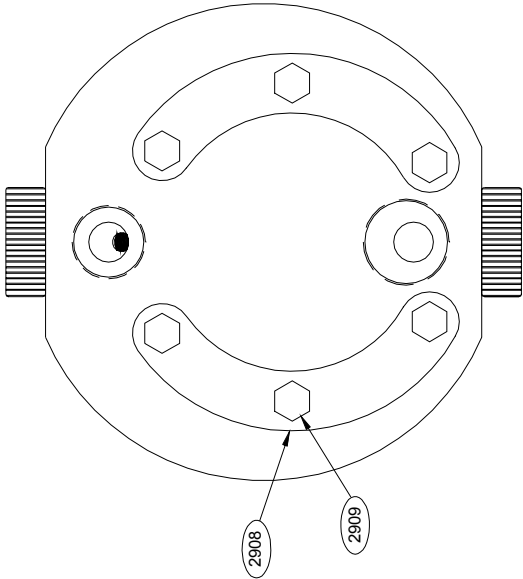
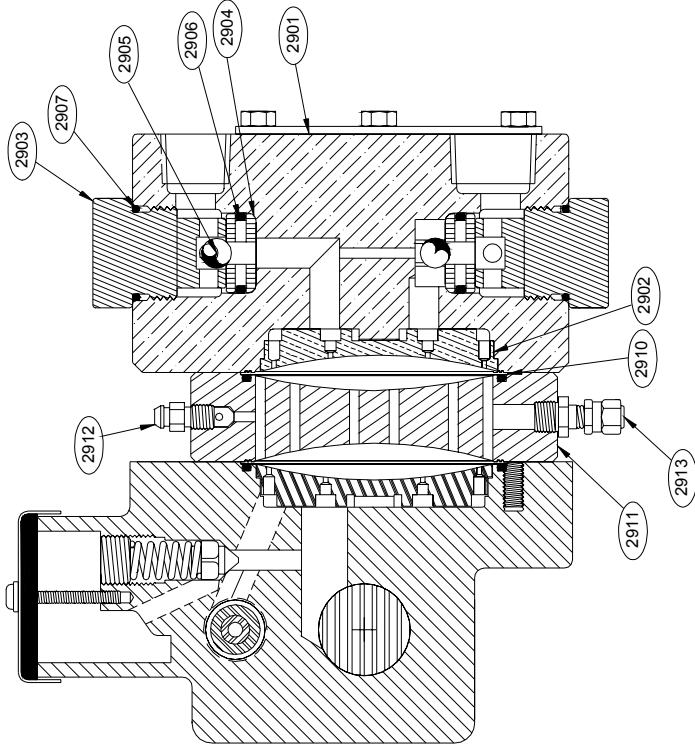

## Liquid End Spare Parts - Degassing Head

The auto-degassing head is specifically designed to meter fluids which tend to degass easily. The self-priming/self-purging head works automatically while the pump is running -- preventing gas accumulation in the pump head, which can lead to reduced capacity and/or problematic startup after shutdown.

Item No.	Qty	Description
1	1	Body, valve
2	1	Outlet, valve
3	1	Retainer
4	1	3/8" ball
5	1	O-ring (-114)
6	1	O-ring (-111)
7	1	O-ring (-203)
8	1	O-ring (-012)
9	1	Nipple connection
10	1	Thrust piece
11	1	Union nut
12	1	Head, diaphragm
13	1	Body, spring return
14	1	Diaphragm
15	2	Ball, check valve
16	2	Seat, check valve
17	1	Spring, return
18	1	Retainer, actuator
19	1	Actuator, diaphragm
20	2	Cap, valve
21	2	O-ring (-042)
22	1	O-ring (-119)
23	2	O-ring (-117)
24	1	O-ring, pump housing
25	2	Bolting plate
26	6	Stud, 1/4-20 x 6-1/2 SS
27	6	Hex nut, 1/4-20 SS
28	1	Spring pin

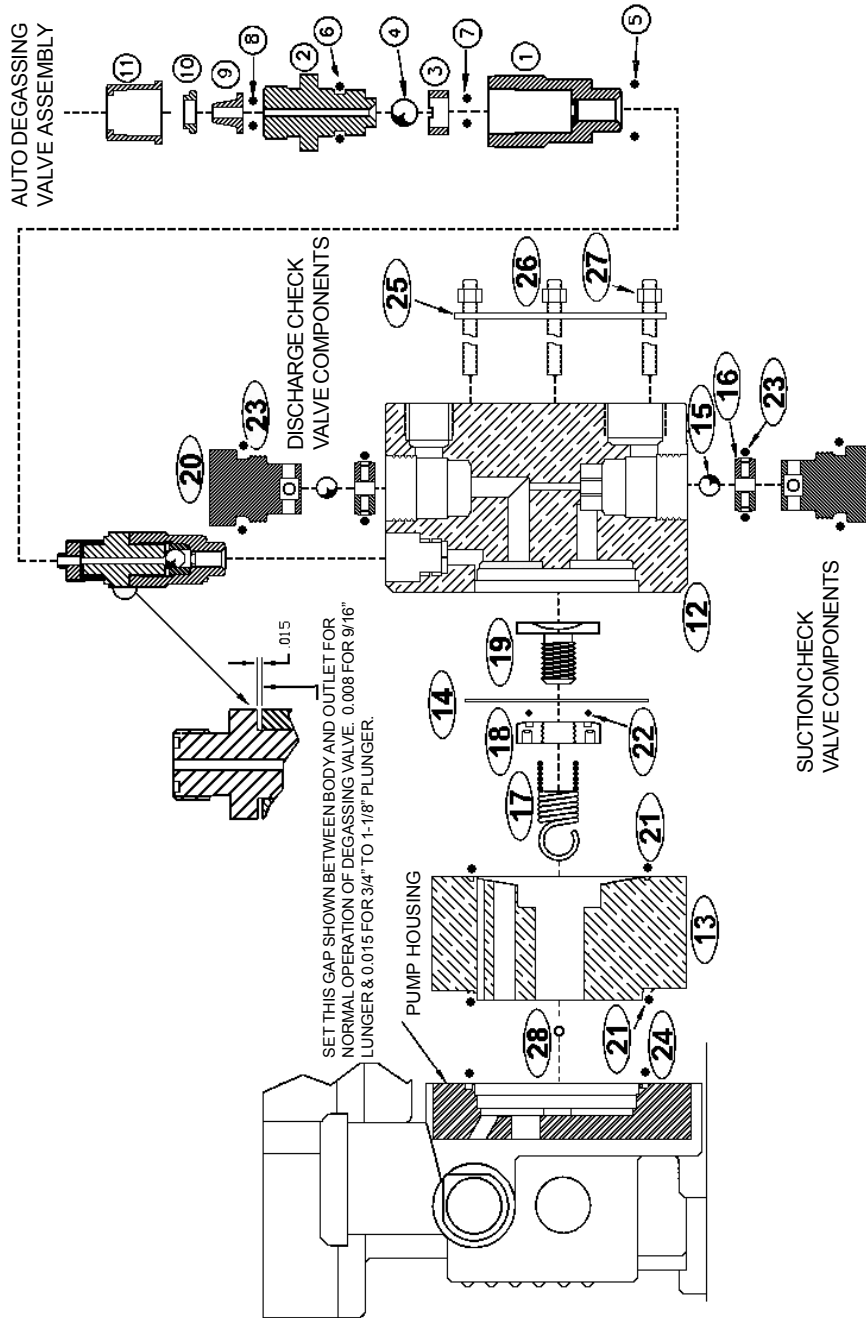

## Installation Schematic - Degassing Head Pump

This typical installation drawing shows the Aquiflow Series 1000 with auto-degassing head installed in a flooded suction condition. The pump can also be installed in a suction-lift condition using a similar piping arrangement. The auto-degassing vent valve must be discharged to atmospheric pressure, and vent tubing should be routed back to the supply vessel or to a drain.

Max. operating discharge pressure: 150 PSIG (1.03 Mpa)

Max. operating temperature: 140°F (60°C)

Max. suction lift (with dry checks): 8' (2.4 m)

Max. suction lift (with wet checks): 20' (6 m)

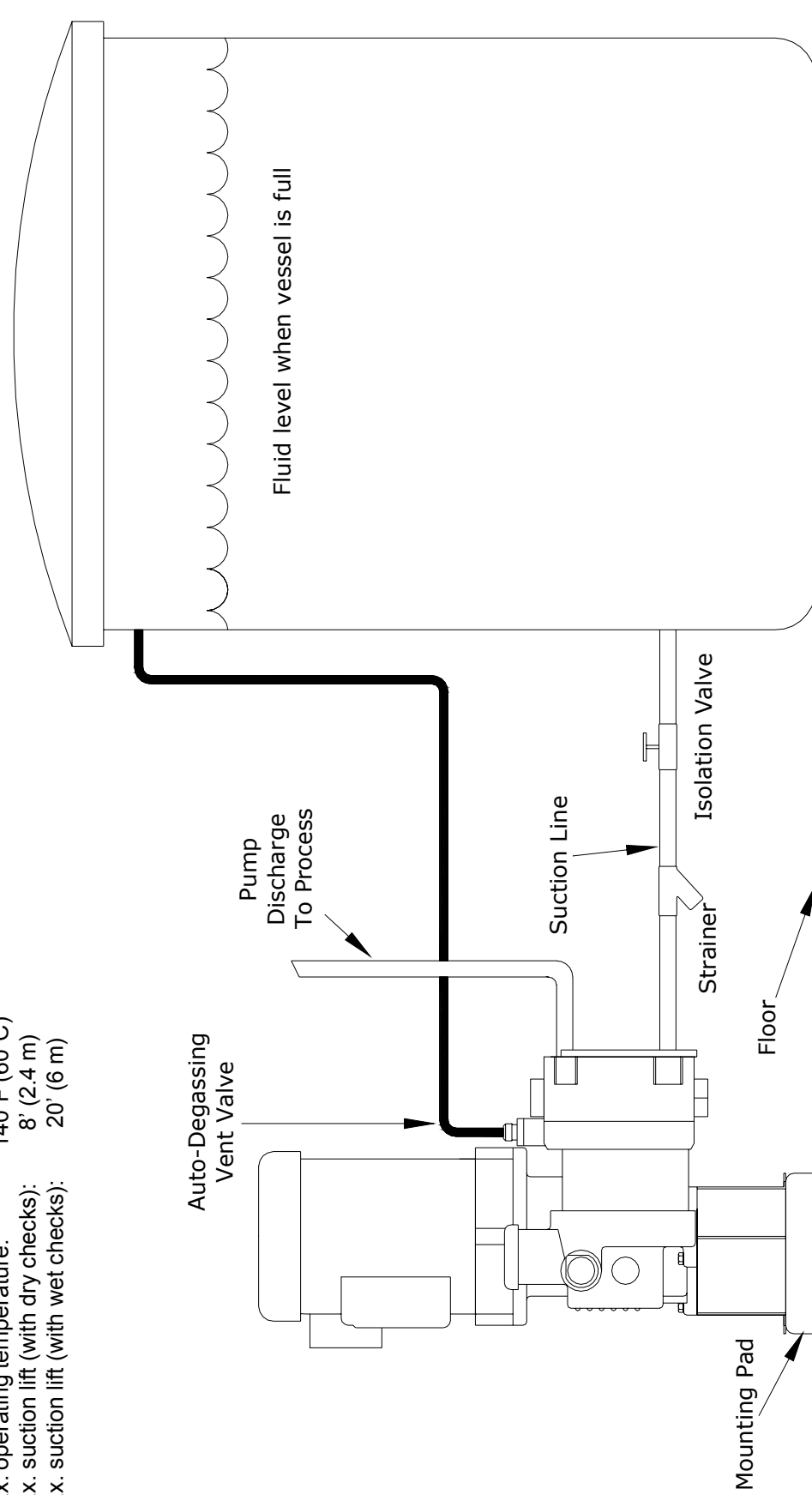

## Pump Troubleshooting Chart

The following charts cover common problems, probable causes and remedies as related to metering pump operation, and will serve as a basis to help isolate and remedy these problems. Each section lists probable causes and remedies in systematic order of probability.

### MOST COMMON STARTUP PROBLEMS

	PROBABLE CAUSE	REMEDIES
<p>Most problems that arise during or shortly after startup are a result of improper pump installation.</p> <p>Each AquFlow pump is tested and in good working order when shipped. Before making adjustments to, or disassembling any part of the pump, check the following.</p>	<ol style="list-style-type: none"> <li>1. Insufficient hydraulic oil.</li> <li>2. Clogged or blocked ball check valves, or check valves held open by solids.</li> <li>3. Clogged/blocked suction strainer.</li> <li>4. System discharge pressure greater than pump relief valve setting.</li> <li>5. Starved suction.</li> </ol>	<ol style="list-style-type: none"> <li>1. Fill to proper level.</li> <li>2. Clean or replace (suction line not flushed prior to connecting pump, permitting debris to enter and block ball check valves).</li> <li>3. Clean or replace.</li> <li>4. Reset internal relief valve within pump rating.</li> <li>5. Insufficient NPSH<sub>A</sub>. Shorten suction piping; increase suction pipe size; increase suction head.</li> </ol>

PROBLEM	PROBABLE CAUSE	REMEDIES
Pump motor fails to start.	<ol style="list-style-type: none"> <li>1. Blown fuse or tripped breaker.</li> <li>2. Open thermal overload.</li> <li>3. Low line voltage.</li> <li>4. Open circuit in limit switches, timers or other control devices in pump motor starter circuit.</li> <li>5. Motor damage.</li> </ol>	<ol style="list-style-type: none"> <li>1. Replace fuse after correcting cause of overload.</li> <li>2. Reset after correcting cause of overload; check heater size.</li> <li>3. Determine cause and correct.</li> <li>4. Reset.</li> <li>5. Check motor for physical damage that may hinder operation.</li> </ol>
Pump runs but fails to deliver.	<ol style="list-style-type: none"> <li>1. Insufficient hydraulic oil.</li> <li>2. Check valve(s) lodged open by solids.</li> <li>3. Worn or dirty ball check valves.</li> <li>4. Suction or discharge line blocked.</li> <li>5. Isolation valve closed.</li> <li>6. Pump is not primed.</li> <li>7. Check valves installed incorrectly.</li> <li>8. Solids build-up between diaphragm and contour plate, limiting diaphragm movement.</li> </ol>	<ol style="list-style-type: none"> <li>1. Fill to proper level.</li> <li>2. Clean or replace.</li> <li>3. Clean or replace.</li> <li>4. Clean line.</li> <li>5. Open valve.</li> <li>6. Allow suction line and pump head to fill with liquid before pumping against pressure.</li> <li>7. Remove and reinstall correctly.</li> <li>8. Remove and clean liquid end, replace diaphragm. An infrequent occurrence when pumping fluid that contains particles that settle out. (A tubular diaphragm liquid end recommended.)</li> </ol>



## Pump Troubleshooting Chart (continued)

PROBLEM	PROBABLE CAUSE	REMEDIES
Pump fails to deliver rated capacity.	<ol style="list-style-type: none"> <li>1. Incorrect capacity setting.</li> <li>2. Insufficient hydraulic oil.</li> <li>3. Starved suction.</li> <li>4. Internal or external relief valve set too low for system conditions.</li> <li>5. Leaky suction piping.</li> <li>6. Excessive suction lift.</li> <li>7. Fluid close to boiling point.</li> <li>8. Fluid viscosity too high.</li> <li>9. Worn or dirty ball check valves.</li> </ol>	<ol style="list-style-type: none"> <li>1. Readjust capacity setting.</li> <li>2. Fill to proper level.</li> <li>3. Increase suction piping size or increase suction head.</li> <li>4. Reset valve to correct setting.</li> <li>5. Repair piping.</li> <li>6. Decrease lift.</li> <li>7. Cool liquid; increase suction head.</li> <li>8. Reduce viscosity of fluid; change ball material; increase ball size.</li> <li>9. Clean or replace.</li> </ol>
Pump operates erratically.	<ol style="list-style-type: none"> <li>1. Clogged/dirty suction strainer.</li> <li>2. Insufficient hydraulic oil.</li> <li>3. Leak in suction piping.</li> <li>4. Internal external relief valve is relieving.</li> <li>5. Insufficient suction pressure.</li> <li>6. Worn or dirty ball check valves.</li> <li>7. Fluid too close to boiling point.</li> <li>8. Fluid viscosity too high.</li> </ol>	<ol style="list-style-type: none"> <li>1. Clean strainer.</li> <li>2. Fill to proper level.</li> <li>3. Repair piping.</li> <li>4. Reset relief valve.</li> <li>5. Raise tank fluid level.</li> <li>6. Clean or replace.</li> <li>7. Cool fluid or increase suction head.</li> <li>8. Reduce viscosity of fluid; change ball material; increase ball size.</li> </ol>
Pump delivers too much capacity.	<ol style="list-style-type: none"> <li>1. Insufficient discharge pressure.</li> <li>2. Too much suction pressure.</li> </ol>	Increase discharge pressure (pump discharge pressure must be 25-30 psig greater than suction pressure to assure proper ball check valve operation).
Noisy operation.	<p>Ball check valves.</p> <ol style="list-style-type: none"> <li>1. Excessive gear wear.</li> <li>2. Improper lubrication.</li> <li>3. Worn bearings.</li> </ol>	<p>Ball valves makes a clicking sound as they operate - rattling noises may also be heard. Under certain conditions these noises are amplified by the natural resonance of piping. These noises are normal and should not cause concern.</p> <ol style="list-style-type: none"> <li>1. Replace gear set.</li> <li>2. Replace with correct oil.</li> <li>3. Replace bearings.</li> </ol>
Motor overheats.	<ol style="list-style-type: none"> <li>1. Motor overloaded - pump operating in excess of discharge pressure rating.</li> <li>2. Improper wiring or low voltage.</li> <li>3. Hydraulic oil too viscous.</li> <li>4. High ambient temperature.</li> </ol>	<ol style="list-style-type: none"> <li>1. Limit discharge pressure to the maximum pressure specified.</li> <li>2. Check power supply.</li> <li>3. Drain/refill with correct oil.</li> <li>4. Increase ventilation or relocate pump.</li> </ol>
Pump leaking oil.	<ol style="list-style-type: none"> <li>1. Oil drain plug loose.</li> <li>2. Pump overfilled with hydraulic oil.</li> <li>3. Diaphragm head bolts loose.</li> </ol>	<ol style="list-style-type: none"> <li>1. Tighten.</li> <li>2. Drain oil to proper level.</li> <li>3. Tighten to specifications.</li> </ol>
Pump losing oil. Hydraulic oil discolored.	Ruptured diaphragm.	Replace diaphragm after correcting cause of failure. Hydraulic oil must be discarded and the pump gearbox thoroughly flushed of all traces of process fluid. Replace with fresh hydraulic oil.

## PARTS ORDERING INSTRUCTIONS

Always have the complete pump model and serial number available when contacting Aquflow for parts or service. This model number can be found on the data plate mounted on the back of the pump housing.

<b>AquFlow<sup>®</sup></b>		
<b>CHEMICAL METERING PUMP</b>		
<b>MODEL</b>	<b>CJ4T 11314-04014</b>	
<b>SERIAL</b>	<b>1234567</b>	
<b>CAPACITY</b>	<b>25.7</b>	<b>GPH</b>
<b>PRESSURE</b>	<b>425</b>	<b>PSIG</b>
Phone: 949-757-1753		
sales@aquflow.com		www.aquflow.com

Should it be necessary to send the pump to the factory for repair or service, thoroughly flush the pump liquid end of all process fluid, drain all hydraulic oil, and call factory for a return authorization number. A material safety data sheet (MSDS) will be required. Pumps returned without authorization number will not be accepted.

Direct all inquiries and orders to your local representative or directly to:

AquFlow  
17865 Sky Park Circle, Unit M  
Irvine, CA 92614  
Telephone: (949) 757-1753  
Fax: (949) 757-1687  
www.aquflow.com  
sales@aquflow.com

FOR YOUR CONVENIENCE, RECORD PUMP SERIAL  
NUMBER HERE: \_\_\_\_\_ .



**Aquflow**  
17865 Sky Park Circle • Irvine, CA 92614  
Phone (949) 757-1753 • Fax (949) 757-1687  
email: sales@aquflow.com  
http://www.aquflow.com

© 2008 PFT

Printed in U.S.A. 11/08