

## HTA Metallic regenerative mag drive turbine pumps

## HTA Pompe a turbina rigenerativa a trascinamento magnetico in metallo

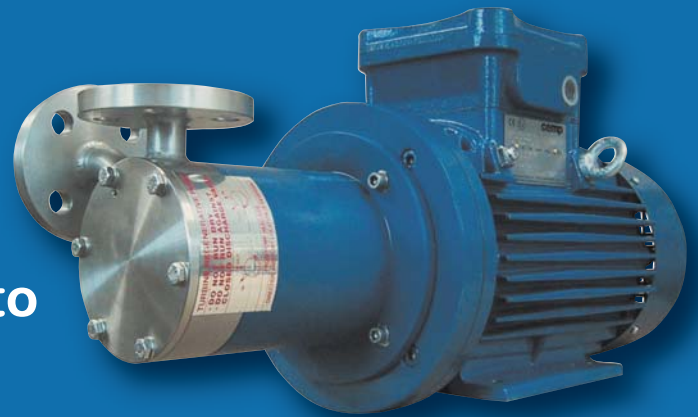

### FEATURES

Mag drive regenerative turbine pumps series HTA are made of AISI 316 or, on request, in other metallic materials (HASTELLOY or TITANIUM) and are suitable for dangerous and inflammable liquids. Thanks to the innovative mag drive system, pumps model HTA reduce the risks of losses and the maintenance costs. The transmission of the motion occurs through magnetic joints without using mechanical seals. This guarantees the maximum hermetic safety and efficiency. The pumped liquid has to be clean and without solids in suspension. Pumps series HTA are also available in ATEX version for zone 1 and 2 (pump model EM-T).

- **High head / low flow capability minimizes by-pass requirements;**
- **Materials available: AISI 316; Hastelloy, TITANIUM;**
- **Materials in contact with the liquid: casing and impeller: stainless steel AISI 316; O-ring EPDM/VITON; bushing: PTFEC; shaft: Hastelloy C276;**
- **Max flow 7 m<sup>3</sup>/h; max head 75 mlc;**
- **Max Temperature: 160°C;**
- **Pressure Rating NP 25 at 20°C**
- **Impeller design handles up to 20% entrained gas. Ideal for pumping liquefied gas.**

### STANDARD

- **Static shaft in HC 276;**
- **Chemical resistant PTFE/Carbon sleeve bearings standard;**
- **High torque magnetic coupling;**
- **Direct starting motors.**

### OPTIONAL

- **ANSI 300 flanges available;**
- **Atex version (pump mod. EM-T);**
- **Explosion proof motor;**
- **Dry-running protection;**
- **Baseplate.**

### CARATTERISTICHE

Le pompe a turbina rigenerativa in metallo a trascinamento magnetico serie HTA sono realizzate in AISI 316 o, a richiesta, in altri materiali metallici (HASTELLOY o TITANIO). Sono adatte al pompaggio di liquidi pericolosi ed infiammabili. Grazie all'innovativo sistema a trascinamento magnetico le pompe HTA riducono al minimo i rischi di perdite e i costi di manutenzione.

La trasmissione del moto avviene infatti tramite giunti magnetici senza l'utilizzo di tenute meccaniche e questa caratteristica garantisce ermeticità del sistema, sicurezza ed efficienza. Il liquido pompato deve necessariamente essere pulito, senza solidi in sospensione. Le pompe della serie HTA sono disponibili anche in versione ATEX per zona 1 e zona 2 (pompa modello EM-T)

- **Alta prevalenza e bassa portata riducono l'utilizzo di by-pass;**
- **Materiali disponibili: AISI 316, Hastelloy, Titanio;**
- **Materiali a contatto con il liquido: corpo e girante: Acciaio Inox AISI 316; O-ring EPDM/VITON; Boccole:PTFEC; Albero Hastelloy C276;**
- **Portata fino a 7 m<sup>3</sup>/h; prevalenza fino a 75 mcl;**
- **Temperatura massima di esercizio: 160°C;**
- **Pressione nominale massima PN 25 a 20°C;**
- **Il design della girante consente di pompare liquidi con presenza di gas fino al 20%. Ideale per il pompaggio di gas liquefatti.**

### STANDARD

- **Albero statico in HC 276;**
- **Boccola rotante in PTFE/Grafite per alta resistenza chimica;**
- **Elevata coppia magnetica;**
- **Avviamento diretto.**

### OPTIONAL

- **Flange ANSI 300;**
- **Versione atex (pompe mod. EM-T);**
- **Motore antideflagrante;**
- **Protezione contro la marcia a secco;**
- **Basamento.**

# HTA 25-37 / EM-T 25-37 (ATEX VERSION) SECTION AND PARTS LIST - SEZIONE E LISTA PARTI

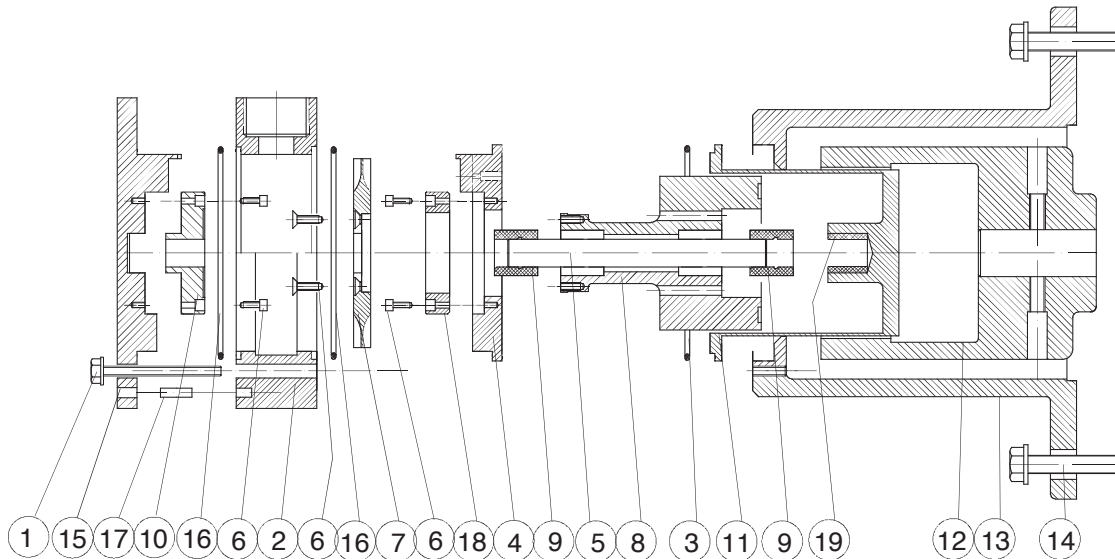

POS.	1	2	3	4	5	6	7	8	9	10	11	12	13	14	15	16	17	18	19
PART. DESCR.	SET SCREWS	PUMP HEAD	O-RING	REAR FLANGE	SHAFT	SET SCREWS	IMPELLER	INT. MAGNET	BEARING	STATIC FRONT RING	REAR CASING	EXT. MAGNET	BRACKET	SET SCREWS	COVER	O-RING	PIN	STATIC REAR RING	REAR BEARING
Materials	AISI304	AISI316	EPDM VITON	AISI316	HAST C276	AISI316	AISI316	AISI 316 NdFeb	PTFEC	PTFEC	AISI316	C40 NdFeb	ALUMINIUM	AISI304	AISI316	EPDM VITON	AISI316	PTFEC	AISI316

# HTA 49-78 / EM-T 49-78 (ATEX VERSION) SECTION AND PARTS LIST - SEZIONE E LISTA PARTI

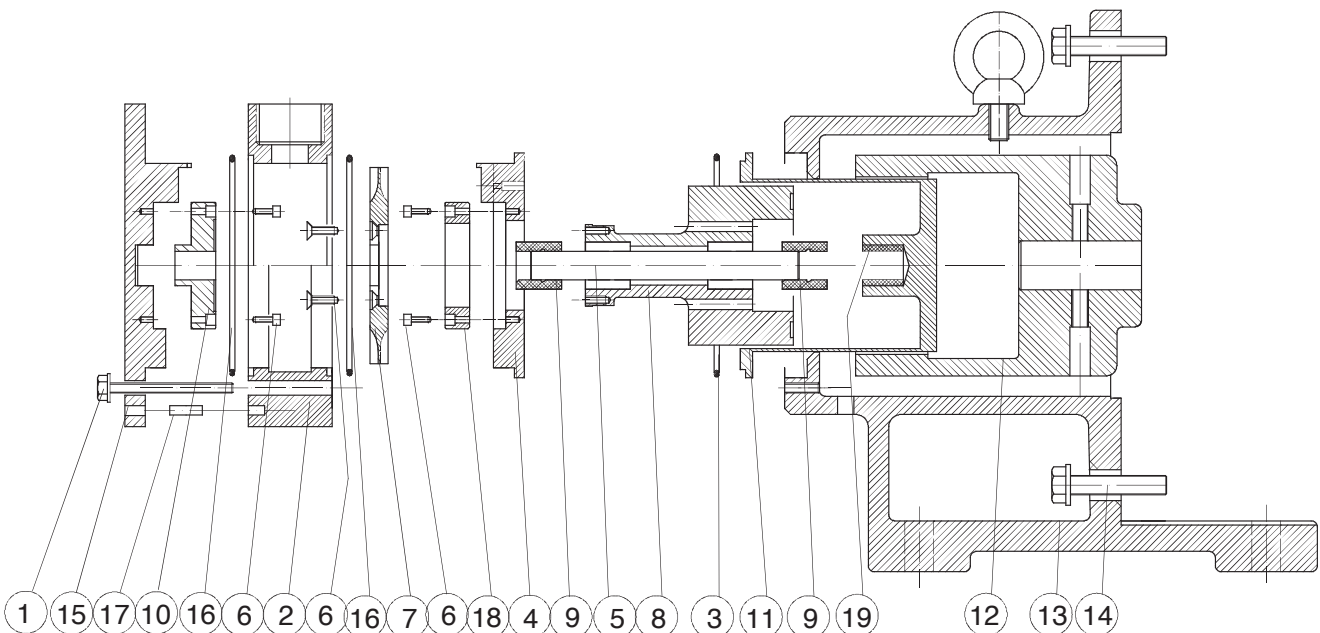

POS.	1	2	3	4	5	6	7	8	9	10	11	12	13	14	15	16	17	18	19
PART. DESCR.	SET SCREWS	PUMP HEAD	O-RING	REAR FLANGE	SHAFT	SET SCREWS	IMPELLER	INT. MAGNET	BEARING	STATIC FRONT RING	REAR CASING	EXT. MAGNET	BRACKET	SET SCREWS	COVER	O-RING	PIN	STATIC REAR RING	REAR BEARING
Materials	AISI304	AISI316	EPDM VITON	AISI316	HAST C276	AISI316	AISI316	AISI 316 NdFeb	PTFEC	PTFEC	AISI316	C40 NdFeb	ALUMINIUM	AISI304	AISI316	EPDM VITON	AISI316	PTFEC	AISI316

# HTA 25-37 / EM-T 25-37 (ATEX VERSION) DIMENSIONS - DIMENSIONI D'INGOMBRO

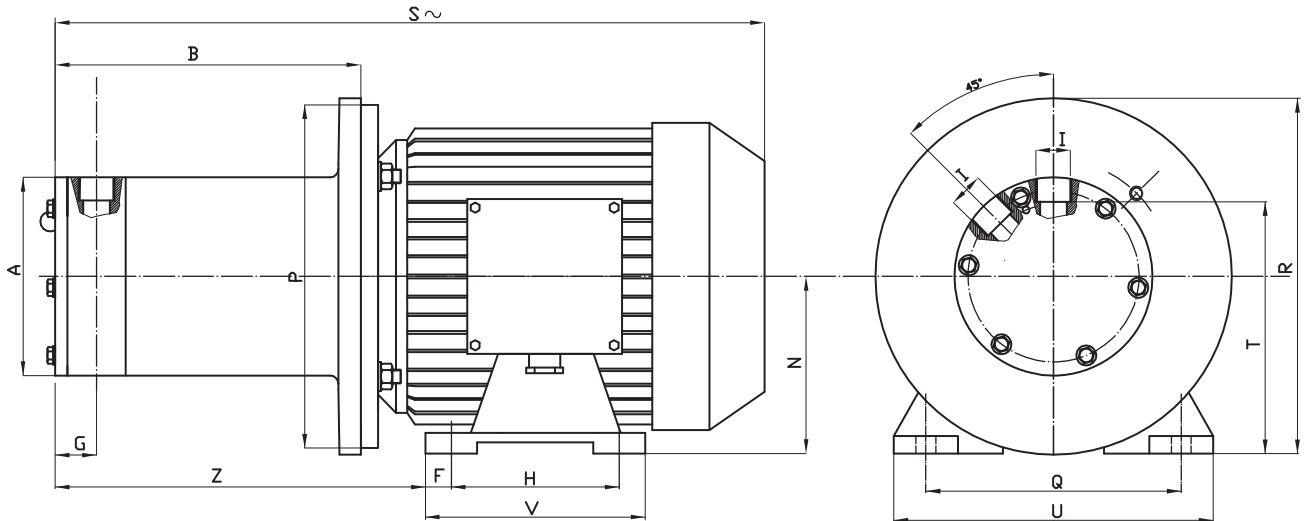

PUMP TYPE	MOTOR	POT. kW	DIMENSIONS - mm -																					
			A	B	C	D	E	F	G	H	I	L	M	N	O	P	Q	R	S~	T	U	V	Z	X
HTA 25	G 80	1,1	123	191	-	-	-	12,5	25	100	3/4" G	-	-	80	-	200	125	180	463	123	154	125	230	-
HTA 37	G 80	1,1	123	191	-	-	-	12,5	25	100	3/4" G	-	-	80	-	200	125	180	463	123	154	125	230	-
	G 90	2,2								125				90		200						140		

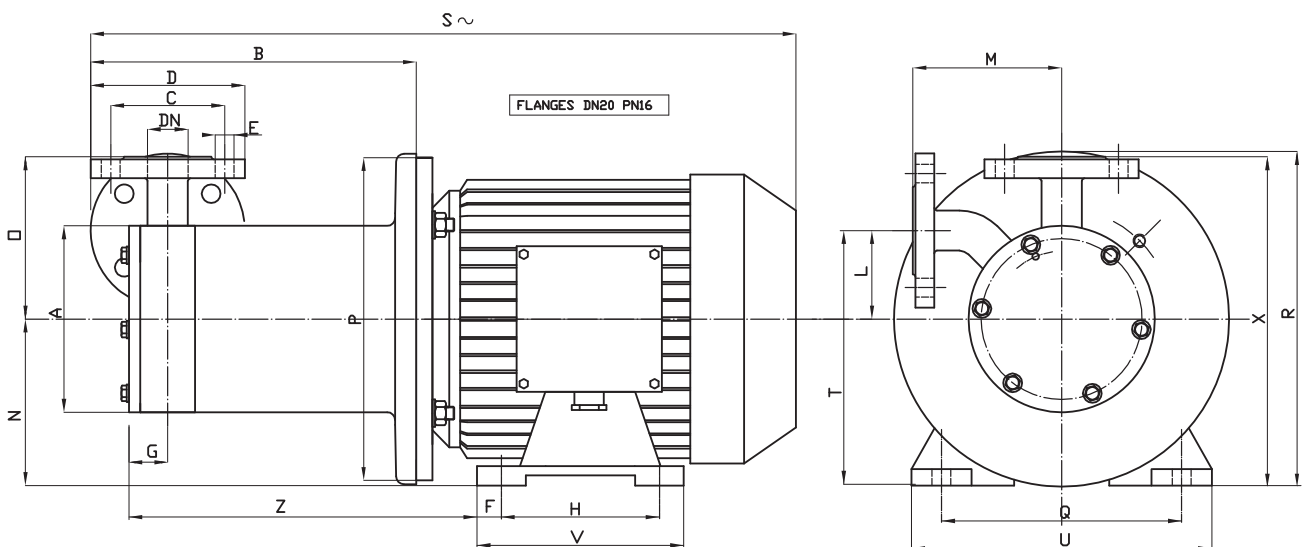

PUMP TYPE	MOTOR	POT. kW	DIMENSIONS - mm -																					
			A	B	C	D	E	F	G	H	DN	L	M	N	O	P	Q	R	S~	T	U	V	Z	X
HTA 25	G 80	1,1	123	218,5	75	105	14	12,5	25	100	20	61	98	80	100	200	125	180	450,5	141	154	125	230	180
HTA 37	G 80	1,1	123	218,5	75	105	14	12,5	25	100	20	61	98	80	100	200	125	180	450,5	141	154	125	230	180
	G 90	2,2								125				90								200		

# HTA 49-78 / EM-T 49-78 (ATEX VERSION) DIMENSIONS - DIMENSIONI D'INGOMBRO

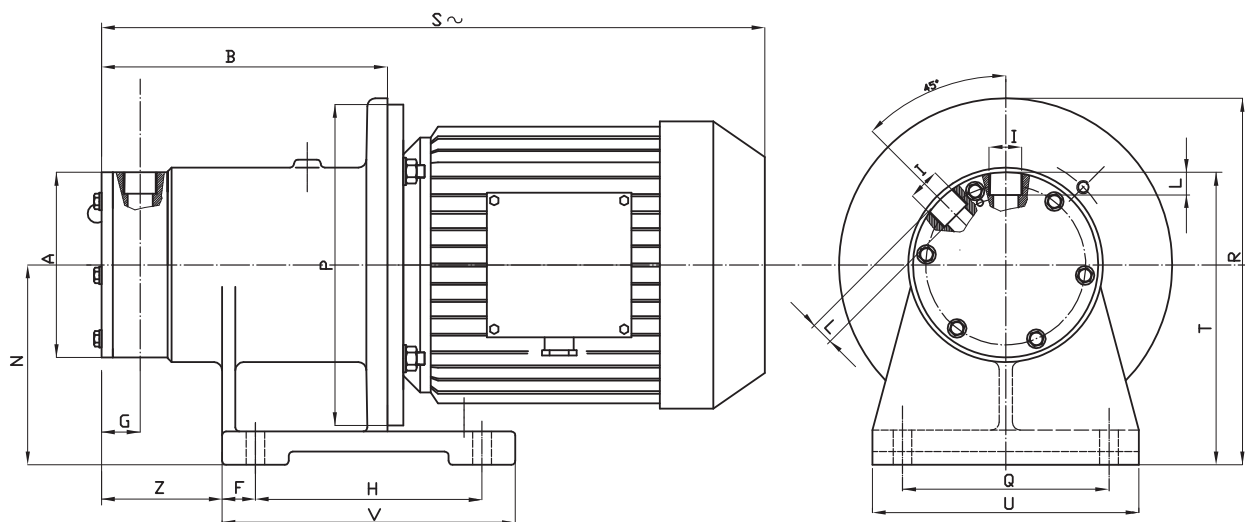

PUMP TYPE	MOTOR	POT. kW	DIMENSIONS - mm -																					
			A	B	C	D	E	F	G	H	I	L	M	N	O	P	Q	R	S~	T	U	V	Z	X
HTA 49	G 90	2,2	139	215	-	-	-	25	29	170	1" GAS	20	-	150	-	200	155	275	471	220	200	220	90,5	-
	G 100	3			-	-	-	25	29	170	1" GAS	20	-	150	-	250	155	275	539	220	200	220	90,5	-
HTA 78	G 100	3	158	225	-	-	-	25	29	170	1" GAS	20	-	150	-	250	155	275	548	230	200	220	92	-
	G 112	4			-	-	-	25	29	170	1" GAS	20	-	150	-	250	155	275	548	230	200	220	92	-

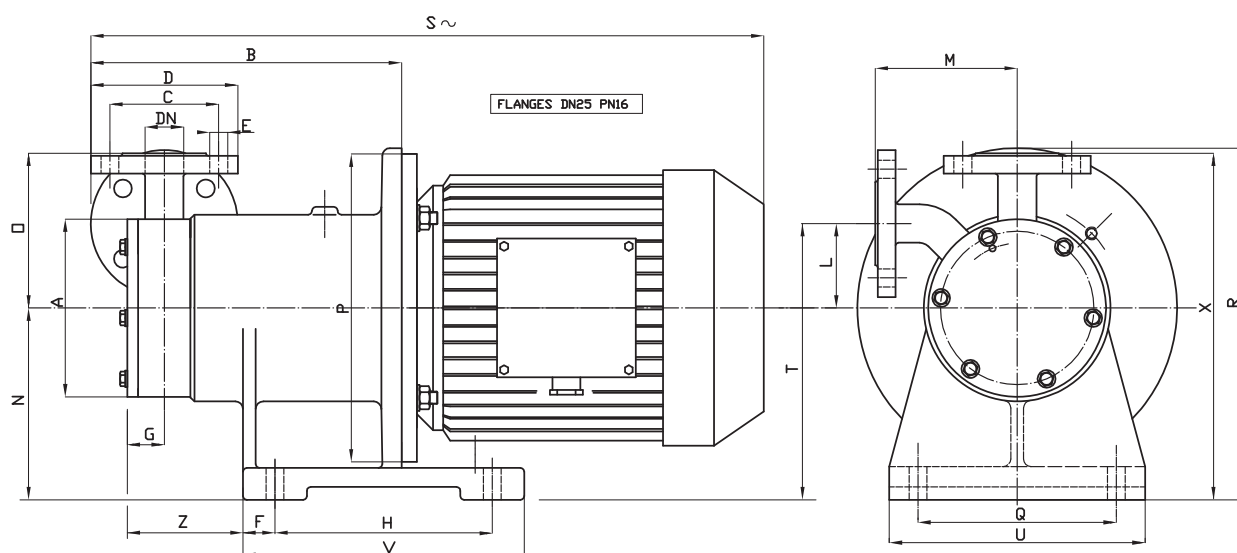

PUMP TYPE	MOTOR	POT. kW	DIMENSIONS - mm -																					
			A	B	C	D	E	F	G	H	DN	L	M	N	O	P	Q	R	S~	T	U	V	Z	X
HTA 49	G 90	2,2	139	243	85	115	14	25	29	170	25	62	111	150	121	200	155	275	523	212	200	220	90,5	271
	G 100	3		253	85	115	14	25	29	170	25	85,5	133	150	133	250	155	275	569	235,5	200	220	92	283
HTA 78	G 100	3	158	253	85	115	14	25	29	170	25	85,5	133	150	133	250	155	275	577	235,5	200	220	92	283
	G 112	4		253	85	115	14	25	29	170	25	85,5	133	150	133	250	155	275	577	235,5	200	220	92	283

# HTA

## 50 HZ - 2900 RPM CURVES - CURVE 50 HZ - 2900 RPM

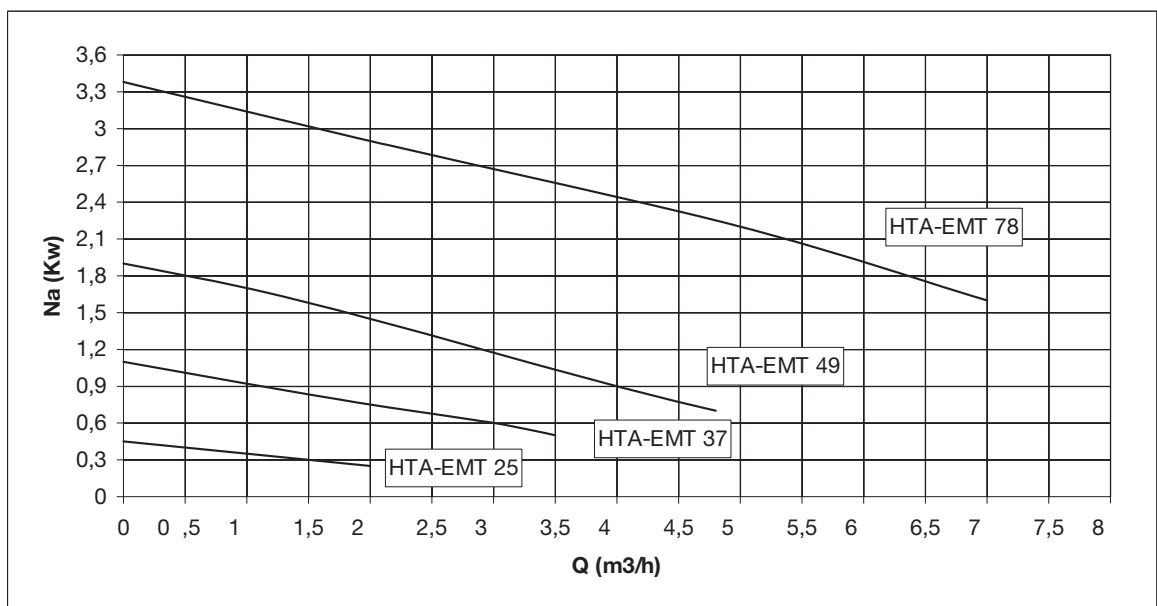
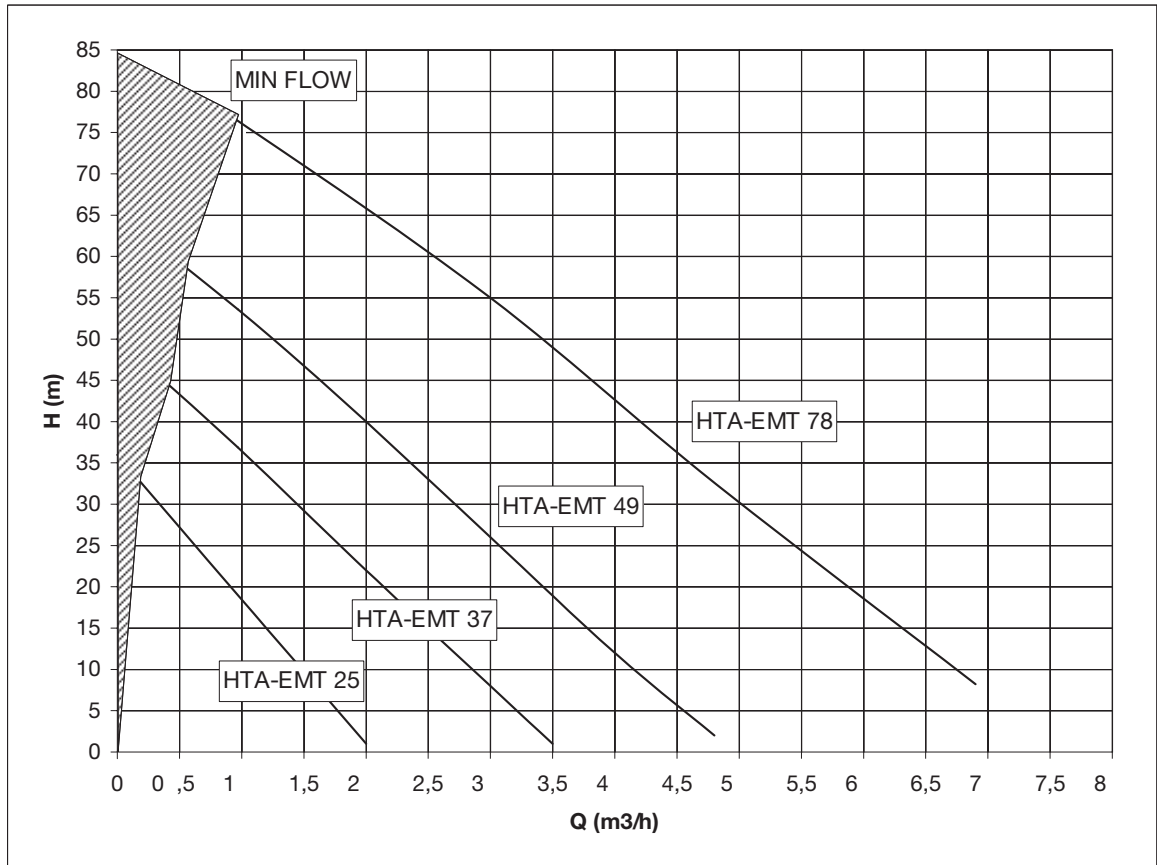

# RANGE OF PRODUCTION - PANORAMA PRODUTTIVO

## HTM PP/ PVDF



### MAG-DRIVE CENTRIFUGAL PUMPS

- **Q max:** 50 m<sup>3</sup>/h - **H max:** 32 mlc
- **Materials:** PP / PVDF

## HTM SS



### MAG-DRIVE CENTRIFUGAL PUMPS

- **Q max:** 30 m<sup>3</sup>/h - **H max:** 24 mlc
- **Materials:** AISI 316

## HTT



### REGENERATIVE MAG-DRIVE TURBINE PUMPS

- **Q max:** 8 m<sup>3</sup>/h - **H max:** 34 mlc
- **Materials:** PP / PVDF

## HTA



### REGENERATIVE MAG-DRIVE TURBINE PUMPS

- **Q max:** 7 m<sup>3</sup>/h - **H max:** 85 mlc
- **Materials:** AISI 316 L / HASTELLOY-C / TITANIUM

## HPP - HPF



### MAG-DRIVE VANE PUMPS SELF-PRIMING

- **Q max:** 400 l/h - **H max:** 5 bar
- **Materials:** PP / PVDF

## HTP



### ROTARY VANE MAG-DRIVE PUMPS DRY SELF-PRIMING

- **Q max:** 2000 l/h - **H max:** 12 bar
- **Materials:** AISI 316 L / HASTELLOY-C / TITANIUM

## HCO



### MECHANICAL SEALED CENTRIFUGAL PUMPS

- **Q max:** 60 m<sup>3</sup>/h - **H max:** 38 mlc
- **Materials:** PP / PVDF

## VPM / VPS / VPL



### LIQUID RING VACUUM PUMPS

- **Q max:** 450 m<sup>3</sup>/h - **H max:** 33 mbar
- **Materials:** AISI 316/316 L SS / ALLOY 20  
HASTELLOY-C / TITANIUM

## PVA



### VERTICAL CENTRIFUGAL PUMPS

- **Q max:** 30 m<sup>3</sup>/h - **H max:** 34 mlc
- **Materials:** AISI 316 / TITANIUM

## HVL



### VERTICAL CENTRIFUGAL PUMPS OPEN IMPELLER

- **Q max:** 55 m<sup>3</sup>/h - **H max:** 36 mlc
- **Materials:** PP / PVDF

## HTF



### DRUM PUMPS

- **Q max:** 130 l/min - **H max:** 22 mlc
- **Materials:** AISI 316 / PP / PVDF

## W 01



### WATTMETRIC RELAY

### DRY-RUNNING PROTECTION