

POMPE DOSATRICI SERIE PKX-MA/A E PKX-MA/AL
NORME DI INSTALLAZIONE, USO E MANUTENZIONE

PKX-MA/A AND PKX-MA/AL SERIES METERING PUMPS
OPERATING INSTRUCTIONS AND MAINTENANCE

POMPES DOSEUSES MODELES PKX-MA/A & PKX-MA/AL
NOTICE D'INSTALLATION, EMPLOI ET ENTRETIEN

BOMBAS DOSIFICADORAS SERIE
PKX-MA/A Y PKX-MA/AL

NORMAS DE INSTALACIÓN, USO Y MANUTENCIÓN

BOMBAS DOSADORAS SÉRIE PKX-MA/A & PKX-MA/AL
NORMAS DE INSTALAÇÃO, USO E MANUTENÇÃO

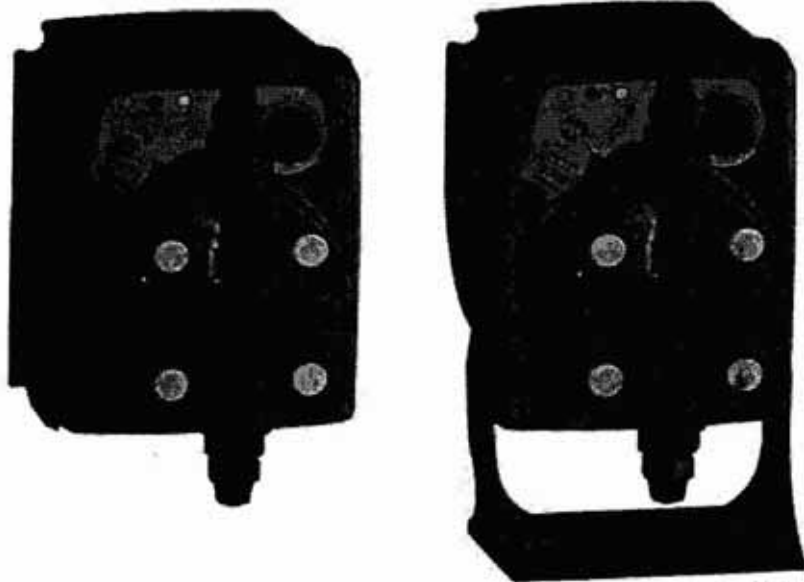

UNI EN ISO 9001:2000
9190.ETAD

ITALIANO

ENGLISH

FRANÇAIS

ESPAÑOL

PORTUGUÊS

INDEX

1.0 - HINTS AND WARNING	pag.12
1.1 - WARNING	12
1.2 - SHIPPING AND TRANSPORTING THE PUMP	12
1.3 - PROPER USE OF THE PUMP	12
1.4 - RISKS	12
1.5 - TOXIC AND/OR DANGEROUS LIQUID DOSAGE	13
1.6 - ASSEMBLING AND DISASSEMBLING THE PUMP	13
2.0 - PKX SERIES METERING PUMPS	14
2.1 - OPERATION	14
2.2 - TECHNICAL SPECIFICATIONS	14
2.3 - LIQUID ENDS MATERIALS	15
3.0 - INSTALLATION	16
3.1 - INJECTION VALVE INSTALLATION DIAGRAM	17
4.0 - MAINTENANCE	18
5.0 - HOW TO OPERATE WHEN DOSING SULPHURIC ACID	18
6.0 - MANUALLY OPERATED METERING PUMP	19
6.1 - PUMP CONTROLS	19
6.2 - TYPICAL INSTALLATION	19
6.3 - ACCESSORIES	19
6.4 - WIRING CONNECTION AND OUTPUT CONNECTOR FUNCTIONS	20
7.0 - TROUBLE-SHOOTING COMMON TO PKX SERIES	20
7.1 - MECHANICAL FAULTS	20
7.2 - ELECTRICAL FAULTS	20
EXPLODED VIEWS	51

1.0 - HINTS AND WARNINGS

Please read the warning notices given in this section very carefully, because they provide important information regarding safety in installation, use and maintenance of the pump.

- Keep this manual in a safe place, so that it will always be available for further consultation.
- The pump complies with EEC directives No.89/336 regarding "electromagnetic compatibility" and No.73/23 regarding "low voltages", as also the subsequent modification No.93/68.

N.B. The pump has been constructed in accordance with best practice. Both its life and its electrical and mechanical reliability will be enhanced if it is correctly used and subjected to regular maintenance.

1.1 - WARNING:

Any intervention or repair to the internal parts of the pump must be carried out by qualified and authorized personnel. The manufacturer declines all responsibility for the consequences of failure to respect this rule.

GUARANTEE: 1 year (the normal wearing parts are excluded, i.e.: valves, nipples, tube nuts, tubing, filter and injection valve). Improper use of the equipment invalidates the above guarantee. Goods on warranty are provided on ex-factory or ex-distributor basis.

1.2 - SHIPPING AND TRANSPORTING THE PUMP

The pump should always be moved in a vertical (and never in a horizontal) position. Regardless of the transportation mode used, delivery of the pump, even when free to the purchaser's or the addressee's domicile, is always at the purchaser's risk. Claims for any missing materials must be made within 10 (ten) days of arrival, while claims for defective materials will be considered up to the 30th (thirtieth) day following receipt. Return of pumps or other materials to us or the authorized distributor must be agreed beforehand with the responsible personnel.

1.3 - PROPER USE OF THE PUMP

- The pump should be used only for the purpose for which it has been expressly designed, namely the dosing of liquid additives. Any different use is to be considered improper and therefore dangerous. The pump should not therefore be used for applications that were not allowed for in its design. In case of doubt, please contact our offices for further information about the characteristics of the pump and its proper use. The manufacturer cannot be held responsible for damage deriving from improper, erroneous or unreasonable use of the pump.

1.4 - RISKS

- After unpacking the pump, make sure it is completely sound. In case of doubt, do not use the pump and contact qualified personnel. The packing materials (especially bags made of plastics, polystyrene, etc.) should be kept out of the reach of children: they constitute potential sources of danger.
- Before you connect the pump, make sure that the voltage ratings, etc., correspond to your particular power supply. You will find these values on the rating plate attached to the pump.
- The electrical installation to which the pump is connected must comply with the standards and good practice rule in force in the country under consideration.
- Use of electrical equipment always implies observance of some basic rules: In particular:
 - 1 - do not touch the equipment with wet or damp hands or feet;
 - 2 - do not operate the pump with bare feet (Example: swimming pool equipment);
 - 3 - do not leave the equipment exposed to the action of the atmospheric agents;
 - 4 - do not allow the pump to be used by children or unskilled individuals without supervision;
- In case of breakdown or improper functioning of the pump, switch off, but do not touch. Contact our technical assistance for any necessary repairs and insist on the use of original spares. Failure to respect this condition could render the pump unsafe for use.
- When you decide to make no further use of an installed pump, make sure to disconnect it from the power supply.

Before carrying out any service on the item, check:

1. Disconnect the pins from the mains or by means of a two poles switch with 3 mm minimum distance between the contacts. (Fig. 4).
2. Relieve all the pressure from the pump head and injection tube.
3. Drain or flush all dosing liquid from the pump head. This operation can also be done with the pump disconnected from the plant by turning the pump upside-down for 15 to 30 seconds and without connecting the tubing to the nipples: if this operation is not possible, dismantle and remount the pump head using the four mounting screws.

In event of possible losses in the hydraulic system of the pump (breakage of the "O" ring gasket, the valves or the hoses) the pump should immediately be stopped and its delivery tube emptied, in accordance with good safety practice (gloves, goggles, overalls, etc.).

1.5 - TOXIC AND/OR DANGEROUS LIQUID DOSAGE

To avoid risk from contact with the hazardous liquids or toxic fumes, always adhere to the notes in this instruction manual:

- Follow the instructions of the dosing liquid manufacturer.
- Check the hydraulic part of the pump and use it only if it is in perfect condition.
- Use only the correct materials for the tubing, valves and seals to suit the liquid to be dosed: where possible shield the tubing with PVC conduit.
- Before disconnecting the metering pump, make sure to flush out and neutralize the pump head with the proper reagent liquid.

1.6 - ASSEMBLING AND DISASSEMBLING THE PUMP

1.6.1 - ASSEMBLING

All metering pumps are normally supplied fully assembled. For greater clarity, please consult the exploded view of the pump appended at the end of the manual, which shows all the pump details and a complete overview of all the pump components. These drawings are in any case quite indispensable whenever defective parts have to be re-ordered. For the same purpose, the appendix also contains other drawings showing the hydraulic parts (pump head and valves).

1.6.2 - DISASSEMBLING

Proceed as follows before you dismantle the pump or before performing any other operation on it:

1. Disconnect the pins from the mains or by means of a two poles switch with 3 mm minimum distance between the contacts. (Fig. 4).
2. Relieve all the pressure from the pump head and injection tube.
3. Drain or flush all dosing liquid from the pump head. This operation can also be done with the pump disconnected from the plant by turning the pump upside-down for 15 to 30 seconds and without connecting the tubing to the nipples: if this operation is not possible, dismantle and remount the pump head using the four mounting screws. (Fig. 10).

This operation calls for special attention, and you should therefore consult the drawings in Appendix and Chapter 1.4 "RISKS" before you commence work.

OVERALL DIMENSIONS (Fig. 1)

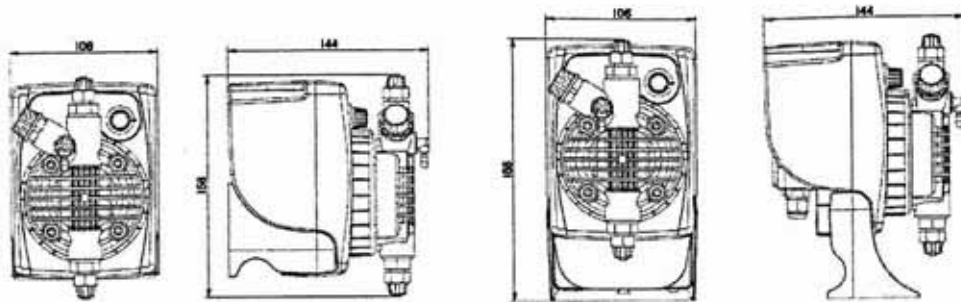

2.0 - PKX SERIES METERING PUMPS

2.1 - OPERATION

The metering pump is activated by a teflon diaphragm mounted on a piston of an electromagnet. When the piston of the electromagnet is attracted, a pressure is produced in the pump body with an expulsion of liquid from the discharge valve. After each pump pulse is finished a spring brings the piston back to the initial position, with a recall of liquid through the suction valve. The operation is simple the pump does not need lubrication, therefore maintenance is reduced almost to zero. The materials used for the construction of the pump make it particularly suitable for aggressive liquids. The metering pump has been designed to feed liquids with capacities from 0 to 20 l/h and pressures from 0 to 15 bar (depending on the model selected).

2.2 - MAIN FEATURES

- The products are manufactured according **CE** regulation.
- Anti-acid plastic casing.
- Control panel protection assured by an adhesive polyester film, weatherproof and resisting UV rays
- Standard power supply (fluctuations not to exceed $\pm 10\%$):
230 V a.c. 50 Hz single phase.
- Optional power supply (fluctuations not to exceed $\pm 10\%$):
240 V a.c. 50-60 Hz single phase;
110 V a.c. 50-60 Hz single phase.
- Overvoltage cat. II.
- Environmental Conditions: IP65 protection, altitude up to 2000m, ambient temperature 5C to 40C, maximum relative humidity 80% for temperatures up to 31°C decreasing linearly to 50% relative humidity at 40°C.
- Pollution degree 2

2.3 - LIQUID ENDS MATERIALS

DIAPHRAGM: PTFE

PUMP HEAD: Polypropylene. Upon request: PVC, 316 Stainless, PTFE, PVDF

NIPPLES: Polypropylene, PVC

FILTER: Polypropylene, PVC

INJECTION NIPPLE: Polypropylene

SUCTION HOSE: PVC - flexible

DISCHARGE HOSE: Polyethylene

VALVES "Lip" type: FPM (viton), (upon request available in EPDM (Dutral), NBR, Silycon). "Ball Check" VALVES upon request type in SS 316 and Class PYREX. Available with Spring Return and "KALREZ" Valve.

SEALS: FPM upon request EPDM (Dutral), NBR, Silycon, PTFE only for ball checks valves

TECHNICAL FEATURES

Tipo Type	Portata max Max flow l/h	Pressione max Max press bar	Max imp./min. Max imp./min.	Dosaggio per isp. Output per stroke ml	Corso Stroke mm	Altez. aspiraz. Suction height m	Aliment. elettr. standard Standard power supply Volts - Hz	Potenza ass. Power comp. Watts	Corrente ass. Current comp. Ampere	Peso netto Net weight kg
1-5	1	5	120	0.14	0.80	2.0	220/240 V 50-60 Hz	32	0.14	1.9
2-6	2	6	120	0.28	0.80	2.0	220/240 V 50-60 Hz	32	0.14	1.9
5-5	5	5	120	0.69	1.10	2.0	220/240 V 50-60 Hz	32	0.14	1.9
7-2	7	2	120	0.97	1.30	2.0	220/240 V 50-60 Hz	32	0.14	1.9
10-1	10	1	120	1.39	1.30	2.0	220/240 V 50-60 Hz	32	0.14	1.9

ENGLISH

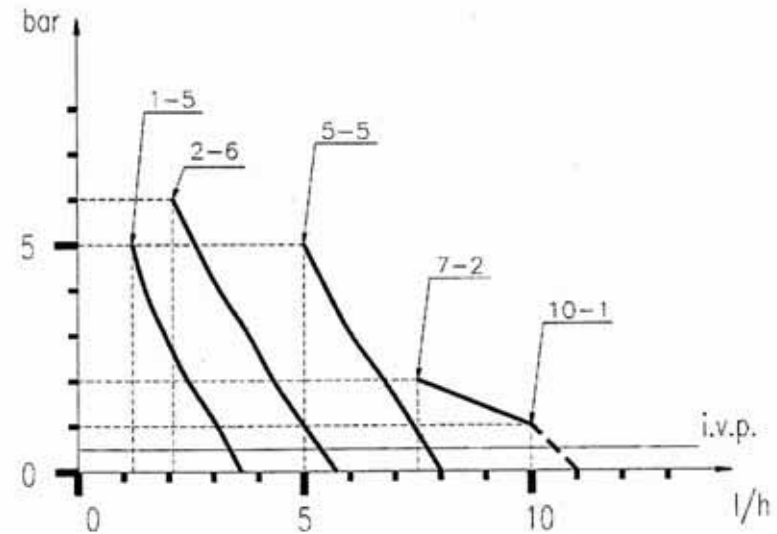

Fig. 2

Fig. 3

The diagrams of fig. 3 indicate max metering pump flow variation in relation to the working pressure in the plant; the diagrams also include injection valve losses. I.V.P. Due to production requirements the technical characteristics of our equipment at maximum ratings can vary with a tolerance of 5% which must be taken into account when choosing the type of pump.

3.0 - INSTALLATION

- a. - Install the pump in a dry environment, with ambient temperatures not exceeding 40°C. The minimum operating temperature depends on the liquid to be pumped, bearing in mind that it must always remain in a liquid state.
- b. - Carefully observe the regulations in force in the various countries as regards electrical installations (Fig.4). When the supply cable is devoid of a plug, the equipment should be connected to the supply mains by means of a single-pole circuit breaker having a minimum distance of 3 mm between the contacts. Before accessing any of the electrical parts, make sure that all the supply circuits are open.

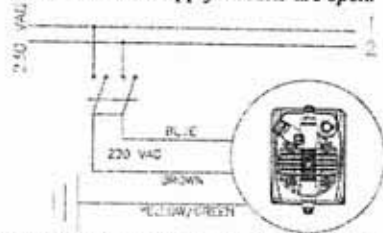

Fig. 4

- c. - Install the pump in any way as shown in Fig. 5. If installed above the chemical tank, it is important that the pump height should not exceed the rated suction height, over the level of the chemical. When the process plant in which the pump is installed is operating at atmospheric pressure (no back pressure) and the chemical tank is situated above the plant (Fig. 6), the condition of the injection valve should be checked at regular intervals, because excessive wear and tear could cause additive to drip into the plant even when the pump is shut down. If the problem persists, install a properly calibrated counter-pressure valve (C) between injection point and the valve. In the case of liquids that generate aggressive vapours, do not install the pump above the storage tank unless the latter is hermetically sealed.

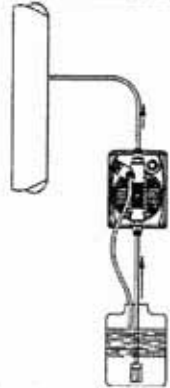

Fig. 5

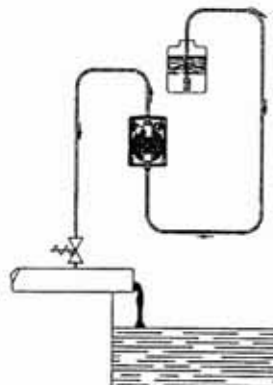

Fig. 6

- d. - The discharge nipple will always remain in the upper part of the pump. The suction nipple, which serves to attach the hose (with filter) leading into the chemical tank, will therefore always be situated in the lower part of the pump.

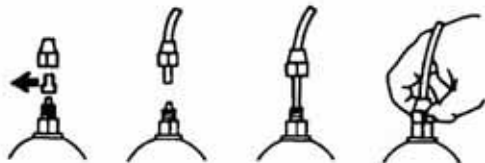

Fig. 7

- e. - Remove the protection caps from the two nipples, slide the hoses over the connectors, pushing them into the maximum, and then fix them with appropriate tube nuts. (Fig. 7).



Fig. 8

- Whenever the pump is dismantled from the pipework, you will be well advised to replace the caps on the connectors to avoid residual liquid being spilled. Before attaching the delivery hose to the plant, prime the metering pump by going through the sequence shown in Fig. 8. Before finalizing the installation of the discharge hose, make sure that the pump strokes will not cause it to move and bump into rigid bodies. In case of priming difficulties, use a normal syringe to suck liquid from the discharge nipple while the pump is in operation, continuing until you actually see the liquid rise in the syringe. Use a short length of suction hose to connect the syringe to the discharge nipple. In case of a pump equipped with an air bleed valve, unscrew the air relief valve B up to all the air in the pump head will be out.
- f. - Try to keep both the suction and discharge hose as straight as possible, avoiding all unnecessary bends.
- g. - Select the most appropriate injection point on a pipe of the plant to be treated and there fit a 3/8" female steel gas thread connector (similar to BSPm). This connector is not supplied with the pump. Screw the injection valve to the gas connector, inserting a gasket as shown in Fig. 9. Then connect the discharge hose to the conical connector on the injection valve and fix it with the supplied tube nut G. The injection valve also acts as no return valve by means of a cylinder sleeve (elastomer, standard supplied in Viton).
N.B. The sleeve D must not be removed.

3.1 - INJECTION VALVE INSTALLATION DIAGRAM (Fig. 9)

- A - Pipework
- C - Injection valve
- M - Conical connector for attaching the discharge hose
- N - 3/8" female steel gas thread connector
- G - Hose tube nut
- T - Polyethylene hose
- D - Cylinder sleeve (no return valve)

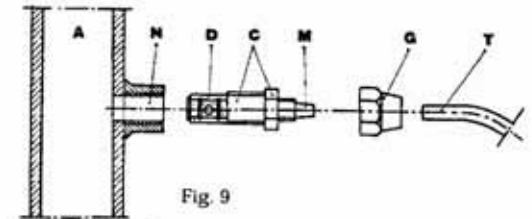

Fig. 9

ENGLISH

4.0 - MAINTENANCE

1. Periodically check the chemical tank level to avoid the pump operating without liquid. This would not damage the pump, but may damage the process plant due to lack of chemicals.
2. Check the pump operating condition at least every 6 months, pump head position, screws, bolts and seals; check more frequently where aggressive chemicals are pumped, especially:
 - pulse and power L.E.D.;
 - the additive concentration in the pipework; a reduction of this concentration could be caused by the wearing of the valves, in which case they need to be replaced (Fig. 10) or by the clogging of the filter which then has to be cleaned as in point 3 here below.

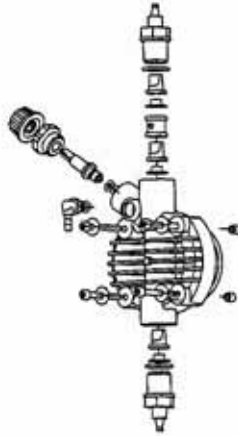

Fig. 10

3. The manufacturer suggests periodically cleaning off the hydraulic parts (valves and filter). We cannot say how often this cleaning should be done as it depends on the type of application, we also cannot suggest what cleaning agent to use as this will depend on the additive used.

Operating suggestions when dosing sodium hypochlorite (most frequent case):

- a - disconnect the pins from the mains or by means of a onnipolar switch with 3 mm minimum distance between the contact.
- b - disconnect discharge hose from pipework;
- c - remove the suction hose (with filter) from the tank and dip it into clean water;
- d - switch on the metering pump and let it operate with water for 5 to 10 minutes;
- e - switch OFF the pump, dip the filter into a hydrochloric acid solution and wait until the acid finishes cleaning;
- f - switch ON the pump again and operate it with hydrochloric acid for 5 minutes in a closed-circuit, with suction and discharge hose dipped into the same tank;
- g - repeat the operation with water;
- h - re-connect the metering pump to the pipework.

5.0 - HOW TO OPERATE WHEN DOSING SULPHURIC ACID (MAX 50%)

In this case it is essential to bear in mind the following:

1. replace PVC crystal suction hose with polyethylene discharge hose;
2. empty any residual water from the pump head beforehand.

Warning: if the water mixes with sulphuric acid it can produce a large quantity of gas with consequent overheating of the area causing damage to valves and pump head.

This operation can also be done with the pump disconnected from the plant by turning the pump upside-down for 15 to 30 seconds and without connecting the hose to the nipples; if impossible, dismount and remount the pump head (Fig. 10) using the four mounting screws.

PKX-MA/A • PKX-MA/AL

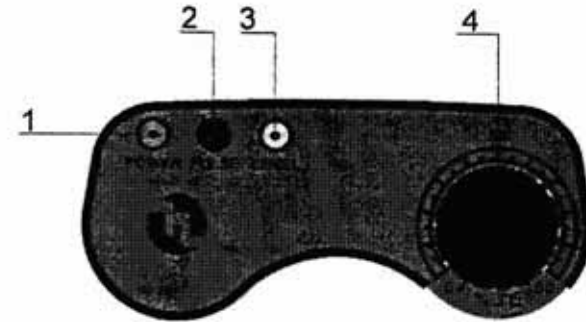

Fig. 11

6.0 - MANUALLY OPERATED METERING PUMP

Flow can be controlled manually by setting the pump pulse rate by means of the knob.

6.1 - PUMP CONTROLS (Fig.11)

- 1 - Power LED "green"
- 2 - Pulse LED "red"
- 3 - Level alarm LED "yellow" (only on version with level alarm)
- 4 - Adjustment knob of injections/min numbers (0+100% max flow)

6.2 - TYPICAL INSTALLATION (Fig.12)

- A Injection valve
C Filter
I Chemical tank
V Process tank

6.3 - ACCESSORIES

- 1 flexible PVC suction hose, transparent crystal type, length 2 m;
- 1 semirigid polyethylene hose, white, 2 m;
- 1 injection valve 3/8 BSP m;
- 1 filter;
- 1 instructions/operating booklet.

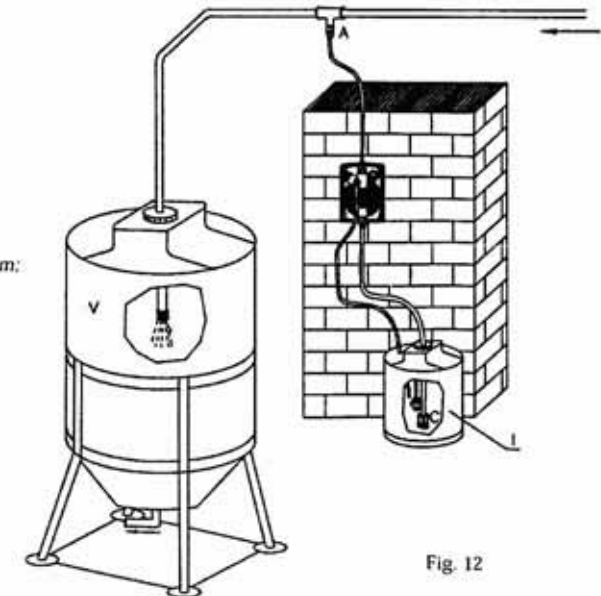

Fig. 12

6.4 - WIRING CONNECTION AND OUTPUT CONNECTOR FUNCTIONS



Model	Female service connector wire assembly	Functions and technical informations
PKX MA/AL		<p>Level probe connection</p> <p>Configuration:</p> <ul style="list-style-type: none"> - Pin 1 = No connection - 2 = No connection - 3 = Level probe wire - 4 = Level probe wire

7.0 - TROUBLE-SHOOTING COMMON TO PKX SERIES PUMPS

7.1 - MECHANICAL FAULTS

As the system is quite robust there are no apparent mechanical problems. Occasionally there might be a loss of liquid from the nipple because the tube nut has loosened, or more simply the discharge tubing has broken. Very rarely there may be losses caused by the breakage of the membrane, or by the membrane seals in which case they have to be replaced by disassembling the four screws of the pump head (fig. 10), when re-mounting the pump head ensure that the screws are replaced properly, along with "O" ring. After repair, the metering pump will need to be cleaned of additive residues which can damage the pump casing.

❶ THE METERING PUMP GIVES PULSES BUT THE ADDITIVE IS NOT INJECTED

- a. Dismount the suction and discharge valves, clean them and replace, see position (fig. 10). Should the valves be swollen, check valves material against our chemical resistance compatibility chart and fit correct valves. Standard valves are Viton. Upon request ball check valve, can be supplied.
- b. Check clogging of the filter.

ATTENTION: When removing the metering pump from the plant, be careful as there might be some residual additive in the discharge hose.

7.2 - ELECTRICAL FAULTS

❶ ALL LEDS OFF, THE PUMP DOES NOT PULSE

Check power supply (socket, plug, power switch ON), if the pump doesn't work contact manufacturer Customer Service, Dealer or Distributor.

❷ GREEN LED (POWER) ON, RED LED (PULSE) OFF, THE PUMP DOES NOT PULSE

Check the flow rate adjustment knob (4), turning it to max flow rate. If the pump doesn't work contact manufacturer Customer Service, Dealer or Distributor.

❸ PUMP PULSES ARE NOT CONSTANT

Check that supply voltage is within +/- 10% of rated voltage.

❹ THE DOSING PUMP GIVES ONLY ONE PULSE

Disconnect the equipment and contact manufacturer Customer Service, Dealer or Distributor.

Serie PKX Series

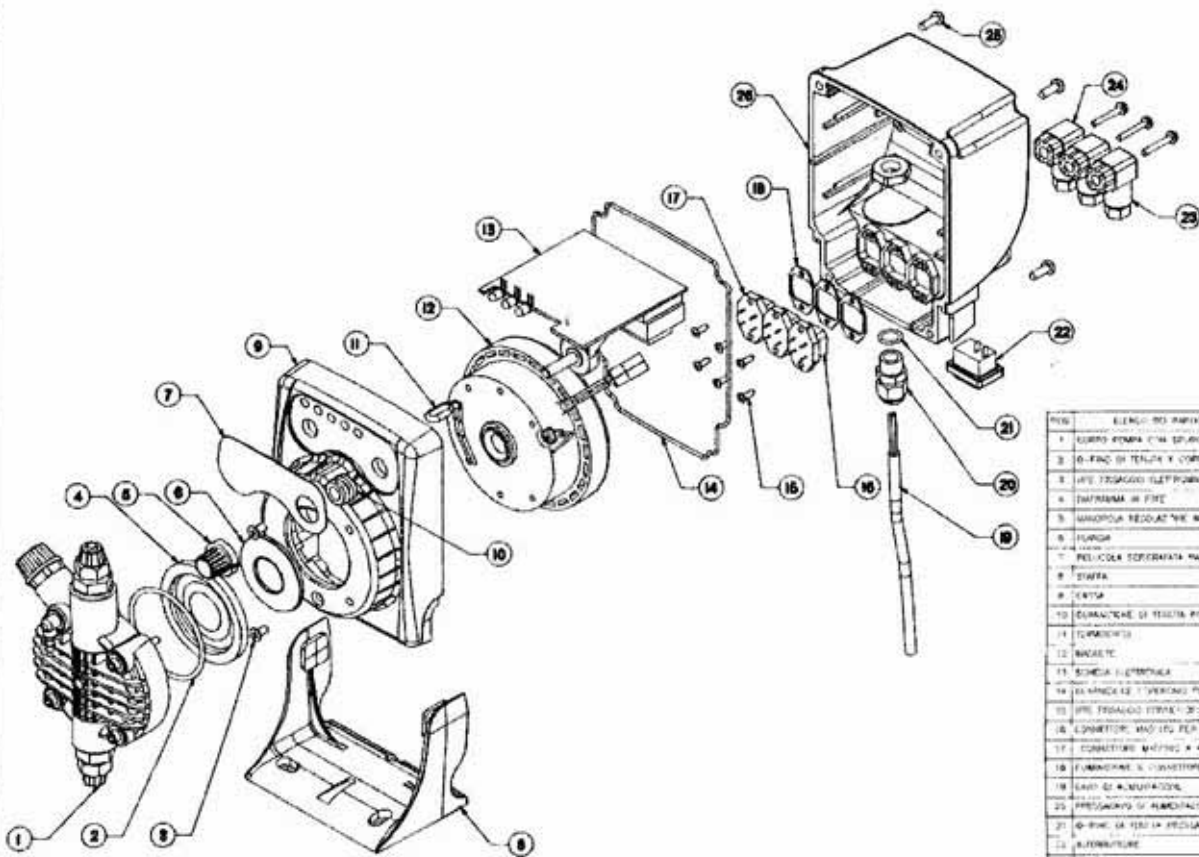

FIG.	ELENCO DEI PARTICOLARI	ENGLISH PART LIST
1	CORPO POMPA CON SPUNTO MANUALE	PUMP HEAD
2	O-RING DI TETRA E CORPO POMPA	FLUOR RING O-RING
3	VITE FISSAGGIO CUFFI POMPA/TESTA	WAVE TIE NUT/BOMBERY SCREW
4	IMPIANTO A FINE	PIPE ZIPPINGS
5	MANOPOLA REGOLAZIONE INTENSITA'	POT. SLIDER ADJUSTER KNOB
6	FRANGI	FRINGE
7	PELLOLA SOPRAPPORATA PARALLELA STRAN	SPONGE, PARAL. SUPERIMPOSED FILM
8	STAFFA	BRACKET
9	CATTA	LATCH
10	ESCLUSIVAMENTE DI TESTA POTENZIOMETRO	POTENTIOMETER CARTRIDGE
11	POTENZIOMETRO	POTENTIOMETER
12	BASELITE	PLATE/SOCKET
13	SCHEDE ELETTRICHE	PC BOARD
14	ARMADURE E TAVOLETTA PROTETTORE	SHIELD COVER LAMINA
15	VITE FISSAGGIO STAFFA 20 - 24 E 5	24/25 TIE NUT/TP SCREW
16	CONNETTORE MASCHILE PER SERVO	OUTLET CONNECTOR MALE
17	CONNETTORE MASCHILE A BRACCIALE R.	PUMP HEAD TIE AND/OR TAIL
18	FILMADRETTA E CONDUTTORE	CONTROL TOP SHEET
19	CAVITÀ ALIMENTAZIONE	POWER LATCH
20	FISSAGGIO DI ALIMENTAZIONE	CABLE CLAMP
21	O-RING DA TESTA FISSAGGIO	CABLE CLAMP O-RING
22	ALTERNATORE	SWITCH
23	CONNETTORE POMPA E SERVO	OUTPUT CONNECTOR PUMP/ST
24	CONNETTORE ALIMENTAZIONE	POWER SUPPLY CONNECTOR (PANEL)
25	BACK COVER SCREW	
26	COPRIFRONTALI	BACK COVER

VALVOLE - VALVES

Valvole di iniezione complete di raccordo

Complete injection valves

VALVOLA INIEZIONE STD fino a 20 l/h
STD INJECTION VALVE up to 20 l/h

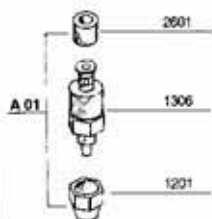

VALVOLA INIEZIONE 90° fino a 20 l/h
90° INJECTION VALVE up to 20 l/h

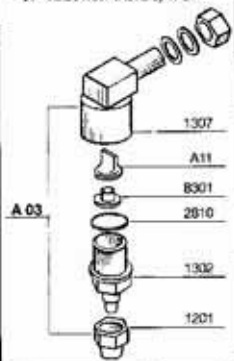

VALVOLA INIEZ. A SFERA fino a 20 l/h
BALL INJECTION VALVE up to 20 l/h

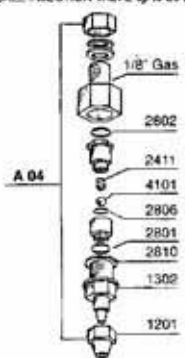

Valvole a labbro - Lip valves

VALVOLA A LABBRIO 20 l/h
20 l/h LIP VALVE

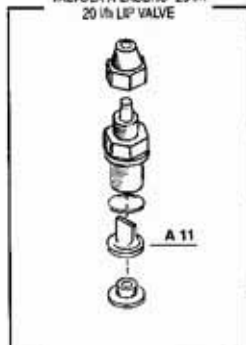

Valvole speciali - Special valves

VALVOLA A SFERA GRAVITÀ 20l/h
20l/h GRAVITY BALL CHECK VALVE

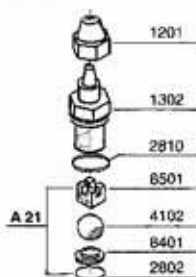

VALVOLA A SFERA ASPIRAZIONE
SUCTION BALL CHECK VALVE

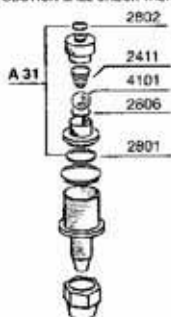

VALVOLA A SFERA MANDATA
DISCHARGE BALL CHECK VALVE

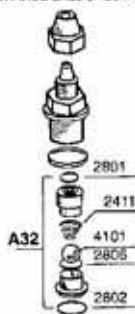

VALVOLA KALREZ
KALREZ VALVE

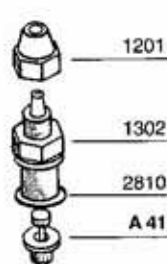

Corpo pompa completo:
P.P. - PVC - Acciaio inox - PTFE
Complete Pump Head:
P.P. - PVC - Stainless Steel - PTFE

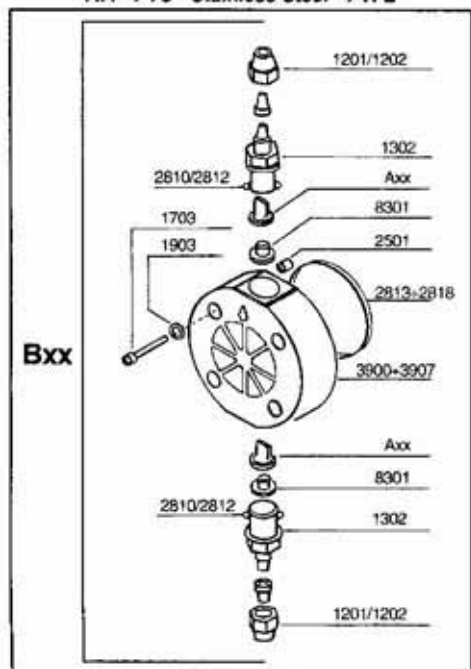

**Corpo pompa con
 spurgo manuale**
**Manual air bleed
 pump head**

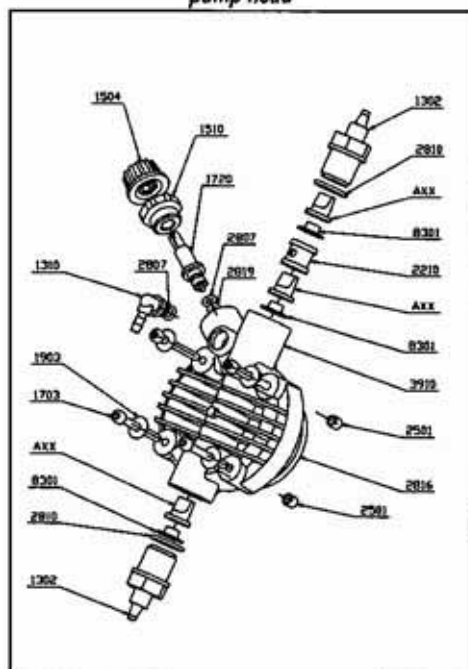

Elettromagnete Completo - Complete Electromagnet

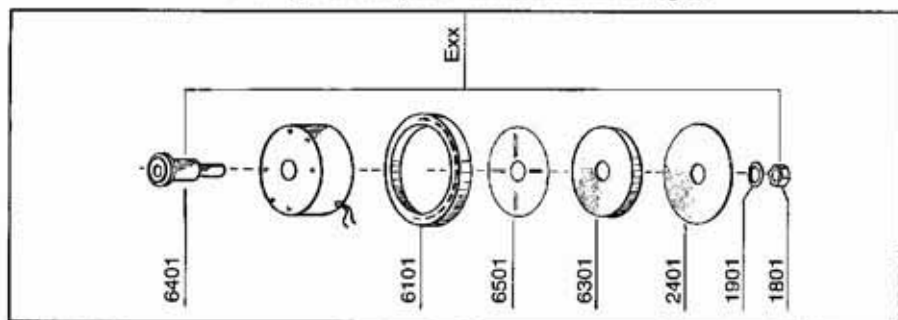

Filtro Std fino a 20 l/h - Std Filter up to 20 l/h

