



**Griffco Valve Inc.**  
6010 N. Bailey Ave., Suite 1B  
Amherst, NY 14226  
Phone: 1 716 835-0891  
Fax: 1 716 835-0893

# INJECTION VALVE QUILL IVQ (Threaded)



## Features:

- High Reliability / Low Cost
- Robust, Machined Construction
- Dual Threaded Connection
- Hastelloy C Spring
- Simplified Design
- Integrated Quill
- High Pressure Metal Configurations
- 6 Material Options

**Griffco** injection check valves feature simplified, rugged design to ensure chemical feed systems inject into the center of a process stream for better mixing and to prevent corrosion along the process pipe. The check valve prevents the process fluid from going back up the chemical line. Robust construction ensures reliability in the rigorous service of municipal and industrial applications. Materials of construction include PVC, CPVC, PVDF, 316SS, Alloy 20 and Hastelloy C. They are available in 1/2", 3/4", and 1" sizes.

## Operation:

**Griffco** injection valves are threaded into a process pipe or tank to deliver chemical to a desired application point. The integrated quill keeps the chemical off the wall of the tank or pipe and will ensure better mixing of the chemical with the process fluid. This is enhanced by the 45° angle at the quill tip. The ball check in the valve functions as a positive shut-off to ensure the process fluid does not go back up the chemical line.

## TYPICAL INSTALLATION

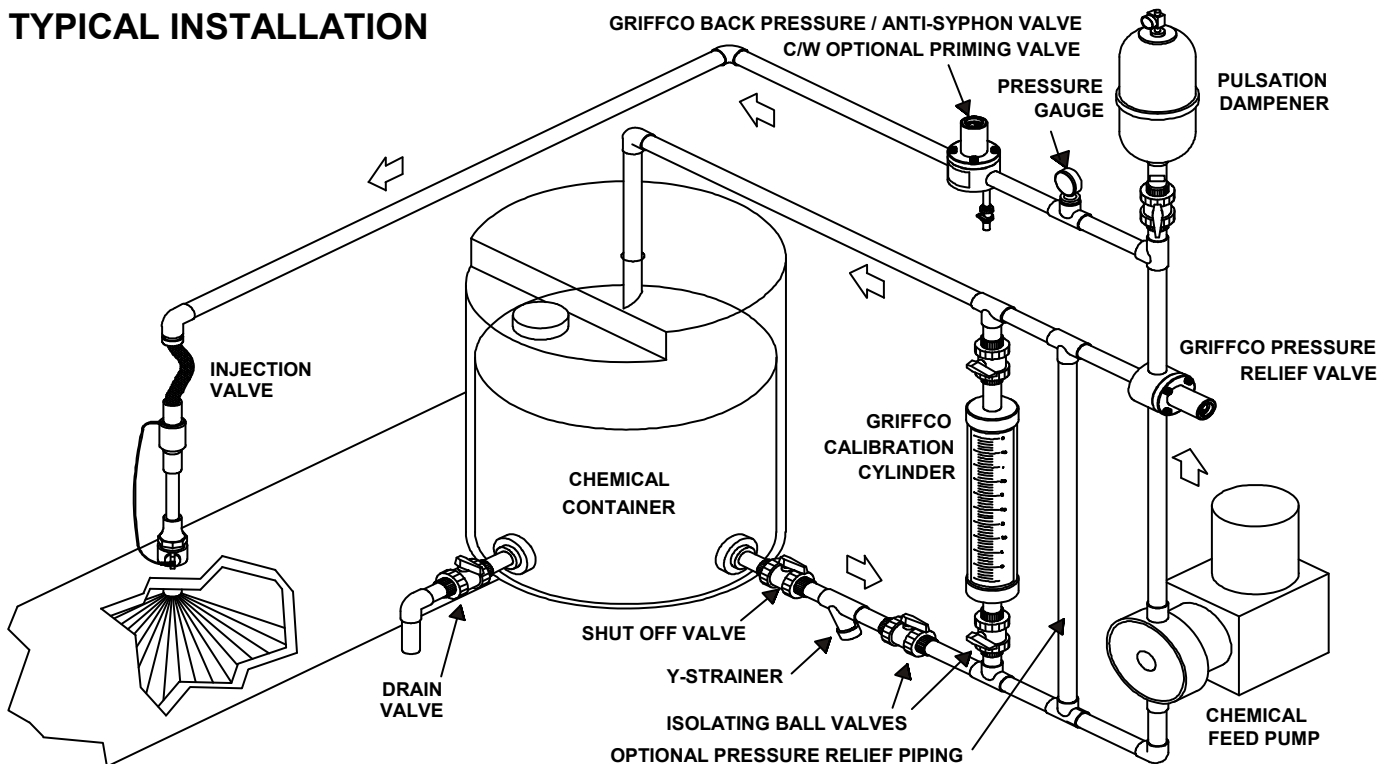

## Technical Data:

Model :	IVQ - Injection Quill (non-serviceable check valve)
Size:	1/2", 3/4", and 1"
Connections:	1/2", 3/4", and 1" NPT Double Thread (Male)
Maximum Temperature:	PVC 140°F (60°C), CPVC & PVDF 195°F (90°C) Metal 400°F (204°C)
Maximum Operating Pressure:	Plastic: 150 psi (10 bar) Metal: 3500 psi (241 bar)
Valve Opening Pressure:	10 psi (0.7 Bar)
Materials of Construction:	
Valve Ball:	Plastic: PTFE Metal: 316SS or Hastelloy C
Spring	Hastelloy C
Valve Body	PVC, CPVC, PVDF, 316SS, Alloy 20, or Hastelloy C

## Dimensions:

Size	A	B	C
1/2"	6.5"	3" *	0.540"
3/4"	7.1"	3" *	0.675"
1"	8.9"	4" *	0.840"

\* Standard length

## Product Codes for Ordering:

IVQ    □ □ □ □ □  
          1    2    3    4

### 1 = Size

050 - 1/2"  
075 - 3/4"  
100 - 1"

### 2 = Material

S - 316 SS  
A - Alloy 20  
C - Hastelloy C  
P - PVC  
K - PVDF  
CP - CPVC

### 3 = Quill Length

Blank - 3" (1/2" & 3/4")  
Blank - 4" (1")

### 4 = Options

Blank - 45° Tip (std)  
(Others by request)

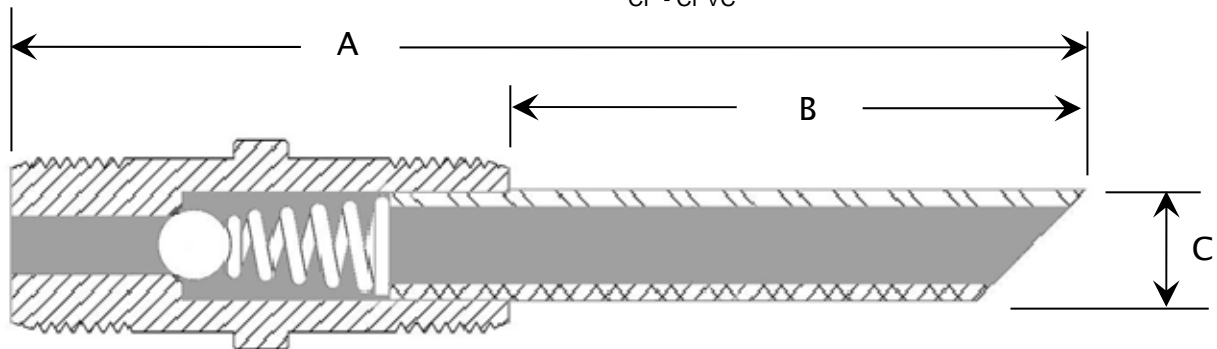

## Face Orientation:

The injection quill releases the chemical by the 45° angle at the quill tip. The bevel surface faces the flow to promote instant mixing of the chemical into the process fluid, except in cases where the possibility of clogging exists.

